

**SALE ENDS  
FEB 15TH**



**CHROME ALUMINUM  
ALTERNATOR PLUG RETAINER**

**\$9.95 EA.**



Attached direct to the engine case to ensure that your plug stays in place and helps prevent any unwanted electrical shorts.

- 53-129** Chrome alternator plug retainer, fits Big Twins 70'-88'.
- 53-130** Chrome alternator plug retainer, fits Big Twins 89'-present.

**BATTERY  
STRAPS**

**\$3.49 EA.**

Made of black rubber.  
**5-220**  
1992/1999 Softail®. 2  
Piece. OEM 66109-93  
& 66111-93.



**MOTORCYCLE  
JUMPER CABLE**

**\$5.95 EA.**



The answer to starting that bike with a dead battery & no kick starter. This set of heavy duty cables measures over 5 feet long and is still compact enough to carry with you.

**97-5** Jumper cables.

**ULTIMA INDIVIDUAL BATTERY CABLES** SOLD EACH

END LUG SIZES		8"	9"	10"	11"	12"	13"
1/4" and 5/16" lugs	<b>SMOKE</b>	<b>18-713</b>	<b>18-714</b>	<b>18-715</b>	<b>18-716</b>	<b>18-717</b>	<b>18-718</b>
	<b>CLEAR</b>	<b>18-743</b>	<b>18-744</b>	<b>18-745</b>	<b>18-746</b>	<b>18-747</b>	<b>18-748</b>
		<b>\$ 8.76</b>	<b>8.97</b>	<b>9.31</b>	<b>9.52</b>	<b>9.73</b>	<b>9.94</b>



**KIDNEY TOOL BOX**

Reproduction OEM style tool boxes complete with original style keys & locks. This is the ultimate addition to any vintage restoration or newly built custom motorcycle.

- 5-91** Kidney tool box, chrome, 1940-1959.  
OEM 64205-40.

**\$27.95 EA.**



**\$10.95 EA.**



**CIGARETTE LIGHTER**

Cigarette lighter and mounting bracket, with wire.

- 18-83** Cigarette lighter; fits any bike.



**ULTIMA® STOCK REPLACEMENT CYLINDER HEADS FOR 74" & 80" SHOVELHEAD**



**\$479.00 EA.**

74"/80" HEADS



C356-T6 Casting. 1.940 stainless Int. Valves. 1.750 stainless Ex. Valves. Manganese Bronze guides. High Silicon Wire Valve Spring with black oxide steel retainers. Compression release valves. 3-bolt exhaust manifold flange for added strength & durability. Dual plug.

**COMPLETE CYLINDER HEADS**

- 93-130 Front natural finish. stock bore, complete.
- 93-131 Rear natural finish. stock bore, complete.

**ROCKER ARM COVERS FOR ALL SHOVEL**



**\$269.95 SET**

With the use of included stud spacers, these covers can be used on both 1966 thru 1981 and 1982 & later models. Replaces OEM 17516-77B, 17517-77B, 17518-80, 17519-80, 17550-80 and 17552-80.

89-344 Chrome plated rocker arm covers and pair of chrome plated stud spacers.

**ULTIMA HYDRAULIC LIFTERS BY JOHNSON**



**\$18.95 EA.**

91-880 Ultima hydraulic lifters for use on 84 & later Big Twins, 1986 thru 1990 Sportsters & Buell 1987 thru 1990.

**EVOLUTION® TAPPET BLOCKS**

**\$69.99 SET**



91-613

These tappet blocks (front & rear) for Evolution® Big Twin 1984 & later are sold with eight chrome plated allen bolts. Replaces OEM 18542-83A and 18540-83A.

- 91-613 Chrome tappet blocks
- 91-697 Chrome tappet blocks for 4"+ bore motor case, used on all Ultima engines 100 C.I. and larger.

**FRONT & REAR CYLINDER FOR PAN 61 & 74 C.I. 1948 THRU 1965**

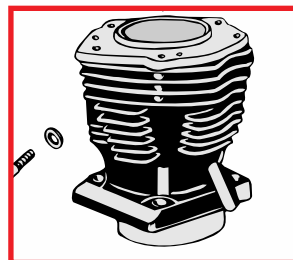

**\$89.95 EA.**

- 93-272 Front 74" Cylinder
- 93-273 Rear 74" Cylinder

**80" CYLINDER FRONT OR REAR FOR EVOLUTION® BIG TWIN 1984 & LATER**

**\$104.95 EA.**

- 93-676 Front or Rear Cylinder; 80 C.I. (OEM 16510-83A)

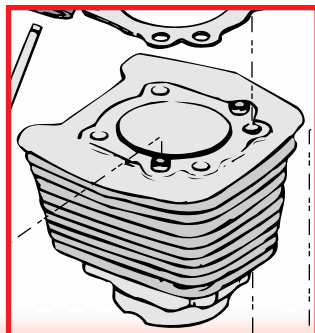

**GEAR COVER FOR BIG TWIN**

Chrome plated cam cover (nosecone) for end oiling pinion shaft.

- 88-53 Fits 1973 thru 1992. Replaces OEM 25258-80B and 25268-84A. **\$54.95 SOLD EACH**
- 88-70 Fits 1993 & later. Replaces OEM 25266-93A. **\$64.95 SOLD EACH**





**FENDER RACK**  
**FOR HERITAGE® & FAT BOY®**      **\$19.99 EA.**

Chrome plated fender rack made from 3/8" steel tubing is perfect for tying up items and protecting paint. Easily installs to stock seat bolt and license plate bracket for quick mounting and removal.

**121-6** Fits Big Twin Heritage® & Fat Boy® models, 1986 & later.

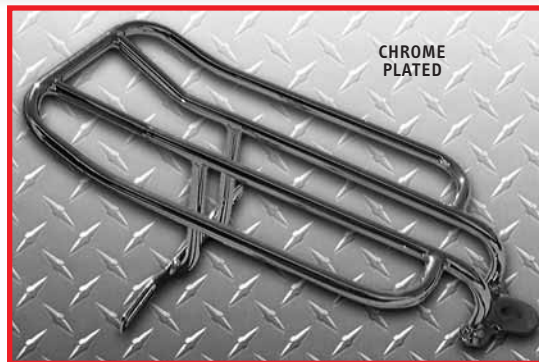

**MOTOR MOUNT STABILIZER**

**\$19.99 EA.**



Fits FXR and FLT, 1984 thru 1994. OEM 16219-79A.

**5-193** Chrome steel Imported.

**AXLE SLIDER KITS**

**\$4.93 KIT**



At last, a sure means of reinforcing and protecting all square section H-D® swing arms and rigid frames from distortion and finish damage by the axle and axle nut. Stainless steel.

**83-19** Fits 4 speed Big Twin 1973 thru 1986, Softail® 1984 & later and Sportster® 1988 & later. Clip-in type.

**THROTTLE ASSEMBLIES**  
**FOR SINGLE/DUAL CABLE**

CHROME  
 PLATED  
 END



Single cable assemblies with adjuster knobs for 1973 thru 1980 H-D® models (OEM 56500-79).

**\$4.95** 35-36 Throttle assembly only. **SOLD EACH**  
**\$7.95** 35-52 Throttle assembly with grips. **SOLD AS PAIR**

Dual cable assemblies with adjuster knobs for 1981 & later FL, FX, XL and most dual cable throttle applications (OEM 56395-81 & 56220-81B).

**\$4.95** 35-43 Throttle assembly only. **SOLD EACH**  
**\$8.95** 35-65 Throttle assembly with grips. **SOLD AS PAIR**

**FRAME MOUNT RIDER PEG BRACKET**  
**FOR BIG TWIN**

**\$17.95 EA.**

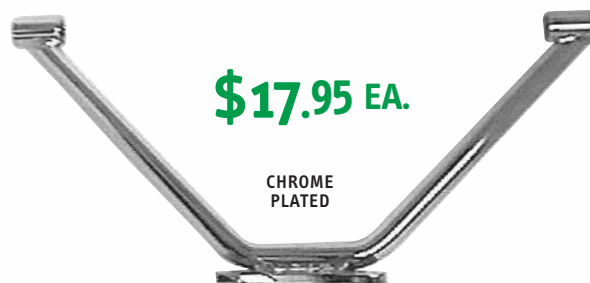

Mounts to transmission plate on H-D® kickstart. May be modified to fit electric start. Gives lower peg location for passenger comfort. Bolt holes for peg mounting are 1/2" diameter.

**23-52** For Big Twin rigid frame.