

City of Northampton
MASSACHUSETTS

In the Year Two Thousand Thirteen

UPON THE RECOMMENDATION OF THE Planning Board

ORDINANCE

An Ordinance of the City of Northampton, Massachusetts, providing that the Code of Ordinances, City of Northampton, Massachusetts, be amended consistent with Sustainable Northampton by revising section 350a and 350b of said code; providing that Column and sections for URB and be deleted and replaced with a separate table that will be combined uses and dimensional regulations for URB

Be it ordained by the City Council of the City of Northampton, in City Council assembled, as follows: That section 350a and b Table Of Uses & Table of Dimensions of the Code of Ordinances of the City of Northampton, Massachusetts, be amended in order to:

Rationale:

Create zoning that reflects existing neighborhood character, bring up to 90% of lots into conformity with zoning, allow more flexibility for expansions and changes to family structure/needs. Encourage reinvestment and preservation of older homes.

So that such section shall:

Delete the Column for URB in 350a and replace it with a separate table as attached to be called Use and Dimensional Regulations URB

Delete entire section of URB in the Table of Dimensions 350b

URB District

Description:

Primarily Residential with Single, Two, Three Family units allowed in different development patterns including townhouse units.

New homes should consist of units that maintain orientation, rhythm, setback pattern and street frontage green patterns of the surrounding block face

Example Structures



Lot Dimension Requirements

Lot Size= 2,500 ft² per unit
 Frontage/Width = 50' Min.
 Depth = 75' Min.

Setbacks

- Front = 10' Min
- Side = 15' Min
- Side = 0' on one side for zero lot line
- Rear = 20' Min

Max Height = 35'
 Open Space = 40%

Layout Setbacks for all uses

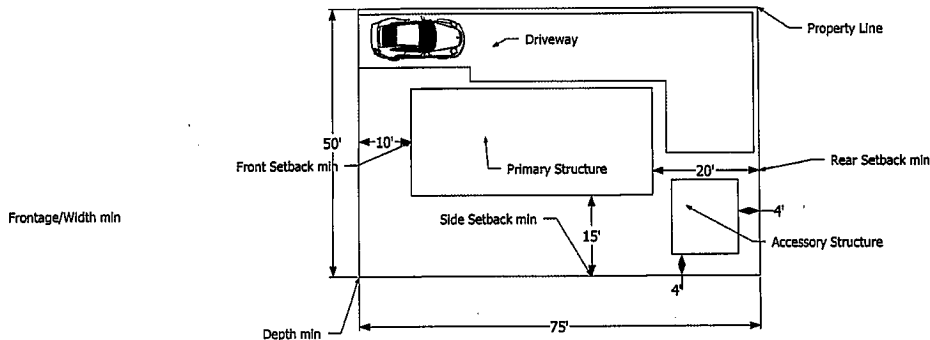

URB Detached House & Accessory Structure layout

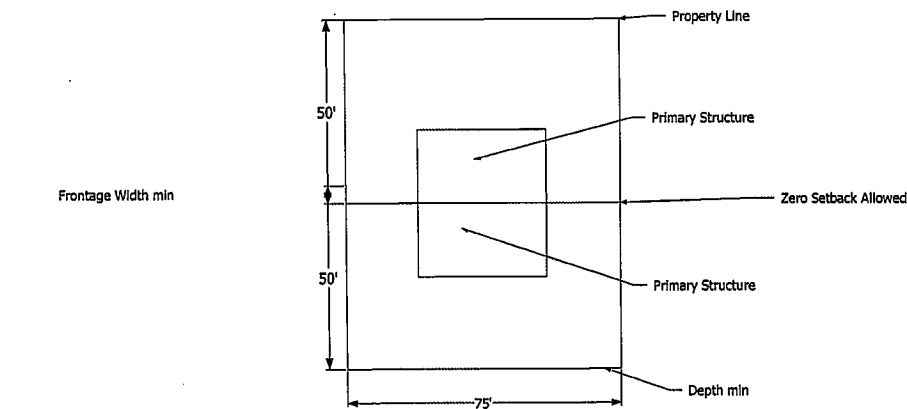



Zero Lot Line

Design Standards Illustrated

Planning Board may waive, by site plan approval elements 2, 3, 4 if it can be shown that a different design meets a pedestrian-scale design that encourages public/private transition and interface (e.g. similar elements facing internal courtyards or private streets)

1. If a garage or other parking structure is attached, it must be set back 20' and the garage/structure shall comprise no more than 30% of the front facade of the primary structure. Side setback may be 10' for the garage only if used as workshop/storage etc.

-  Primary Structure
-  Garage or Parking Structure
-  Area

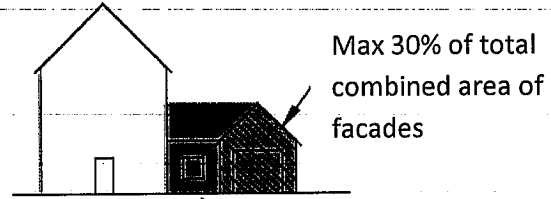

Connector elements must be set back & include glazed openings that face the street

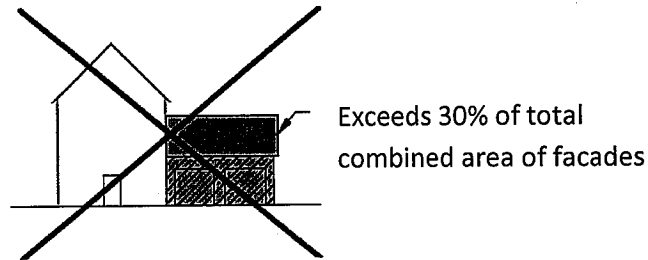
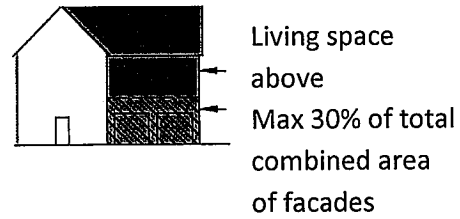
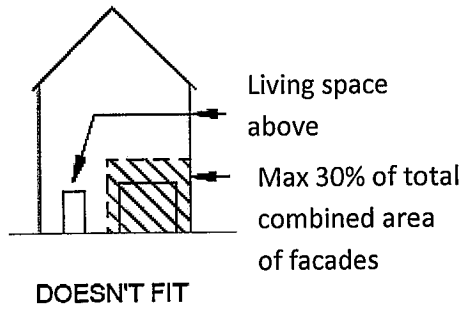

2. Buildings must have a covered entry.

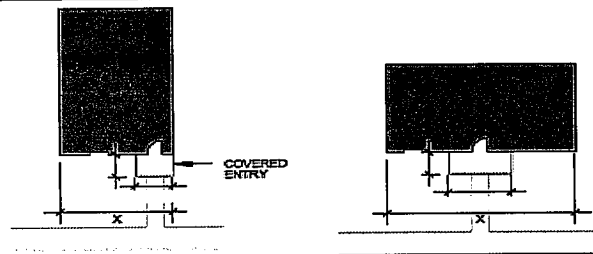

3. For new buildings, setback, scale, massing should fit within the block face.

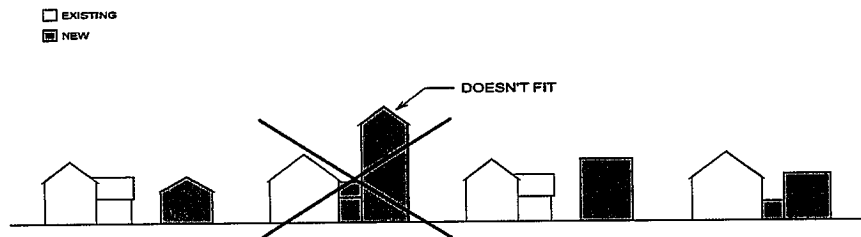

4. Parking for more than 5 cars shall be distributed on the site to minimize impact to the neighborhood character: Accomplished by small groupings of spaces surrounded by landscaping or parallel parking along a narrow driveway to mimic an alley.

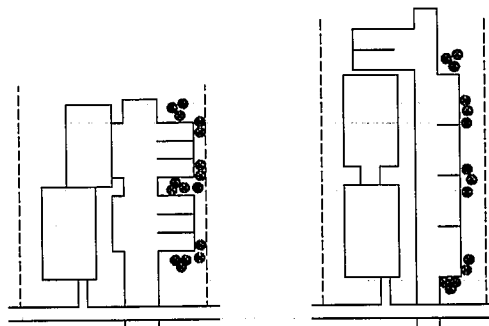

Minimum Parking for residential uses	1 space per 1,000 ft ² Gross Living Area (round up). No more than 2 spaces required per unit.
For other uses see table in 350-8.2	Front yard setback may only have parking for a maximum of two vehicles

URB USES ALLOWED

Uses Allowed By Right:

- Single, Two, Three Family Dwellings
- Attached(to a single family) accessory dwelling unit not to exceed 900 F² Gross Living Area. See 350-10.10. Same setback as for principal structures.
- Home Business up to 25 visits per week as defined in sect.2.1
- Zero Lot Line Single Family see section 350-10.14
- Preexisting nonconforming uses (may trigger ZBA permit)
- Accessory uses to residential: Tag Sales -temporary sales of personal and household articles, Pets/animals section 5.3
- Accessory structures- detached (but no larger than 1,000 ft² of lot coverage or 3% of lot area whichever is greater unless it is used for agricultural purposes) See also § 350-6.7. Setbacks: 20'(front), 4' (side), 4' (rear)
- Family day care (registration w/Building Commissioner required)
- Cemetery
- Temporary event as defined in 350-2.1
- Municipal facility, Facilities for essential services
- Agriculture, horticulture, floriculture, noncommercial forestry, the growing of all vegetables and a temporary (not to exceed erection or use for a period of four months in any one year) greenhouse or stand for retail sale of agricultural or farm products raised primarily on the same premises
- Rooftop solar hot water and photovoltaic
- Accessory solar photovoltaic(PV) ground-mounted on a parcel with any building/ use, provided that the PV is sized to generate no more than 100% or 8 KW of the annual projected electric use of the non-PV building/use. Same setbacks as for detached accessory structures.
- Solar photovoltaic of any size, ground-mounted over any legal parking lot or driveway

Site Plan Approval required for the following:

- Any Construction (other than for a single family home) greater than 2,000 ft²
- Townhouses
- Educational use: non-profit, dormitories, any religious use, day care, school-aged child-care program (MGL c. 28A, § 9) and Historical association or society and nonprofit museum (may include the residence of a caretaker)
- Reuse of Historic Educational or Religious Building for: Any residential use, live/work space, or office, provided however that no more than 20% of the floor space of the building shall be used for medical, banking or any offices where a primary function is to provide services to retail customers or individuals; and further provided that such use is within the footprint of existing building. The existing building may be expanded to accommodate elevators and stairwells, provided that all historically contributing portions of the building are retained and covered with a Historic Preservation Restriction granted to the City of Northampton in a form acceptable to the Planning Board, with input from the Historical Commission, as preserving the key character defining features visible from the road (and not necessarily meeting federal or state preservation standards for the entire building). Portions of the building that are not part of the original architecture of the building and which do not contribute to the historical or architectural significance of the building as determined by the Planning Board, with input from the Historical Commission, may be demolished.
- Cluster development. See below for lot layout standards and § 350-10.5 for other required criteria.
- Parking off site and combined parking. See § 350-8.5 and 350-8.7
- Creation or expansion of more than six parking spaces.
- Parking lot access for nonresidential uses across a residential lot. See § 350-8.9.
- Parking requirement reduction. See § 350-8.10F.
- Residential Shared driveways see § 350-8.8R
- Private Utility, substation or district utility, small scale hydro electric generation.
- Year-round greenhouse / stand for wholesale and retail sale of agricultural farm products raised on site
- Telecommunication antennas (cellular phone) located on existing telecommunications towers or other structures which do not require the construction of a new tower (in accordance with § 350-10.9)

Special Permit Approval required for the following uses by Planning Board unless otherwise noted:

- Detached Accessory Dwelling Unit see 10.10—*Zoning Board of Appeals Special Permit*
- Home Business for personal service business by appointment only or Home Business more than 25 visits etc. see 10.12 for other criteria—*Zoning Board of Appeals Special Permit*

- Educational use -Private for-profit colleges, schools, etc
- Community Center,
- Lodging House, halfway house,
- Bed & Breakfast/ Tourist Home
- Nursing Homes, Assisted Living
- Membership club operated as a not-for-profit corporation, as defined by MGL c. 180, excluding any adult establishments which display live nudity
- Filling of any land. See § 350-10.4.
- ~~Filling of water or wet area. See § 350-10.3.~~
- Funeral establishment
- Crematory
- Accessory solar photovoltaic ground-mounted on a parcel with any building or use, between 8 KW or over 100% but no more than 200% of the annual projected electric use of the non-PV building or use
- Heavy public use. See § 350-10.7.—*City Council Special Permit*

- Cluster development Layout Standards
 - a. Project Lot= 2 Acre Min
 - b. Project Frontage=50'
 - c. Project Depth= 100'
 - d. Setbacks from Project Boundary: Front =10' Side= 15 Rear= 20'
 - e. Individual lot frontage, setbacks, frontage = 0'
 - f. Max Height = 40'
 - g. Project Open Space = 50%
 - h. Design: Planning Board to review layout to ensure project transitions between existing neighborhood along street and proposed project. For new buildings, setback, scale, massing should fit within the block face. Mature specimen trees shall be preserved unless shown to be infeasible. No minimum setbacks, lot size, frontage, or open space for internal lots. More than one structure may be located on a single lot.