

May 6, 1958

R. R. DRISCOLL
GLOW INDICATING TUBE

2,833,949

Filed Dec. 13, 1955

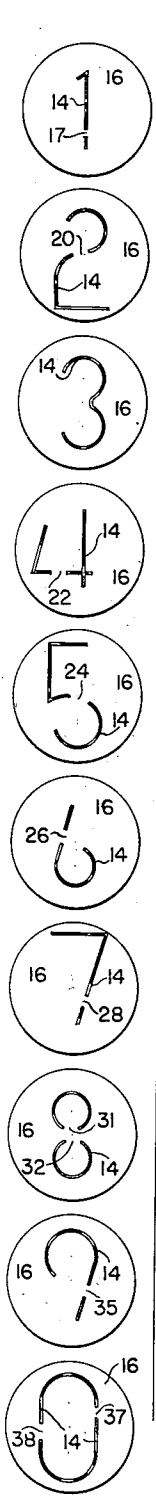

Fig. 4

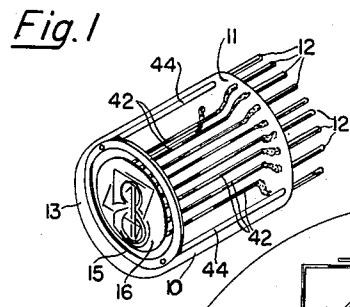

Fig. 1

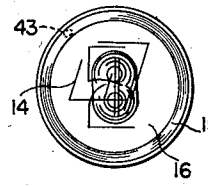

Fig. 1a

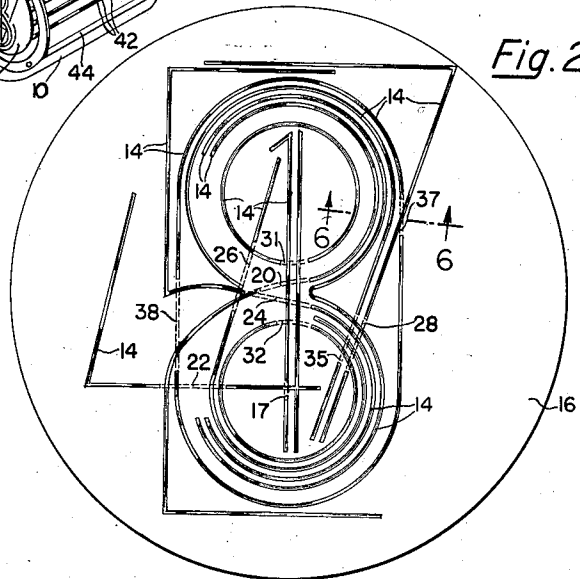

Fig. 2

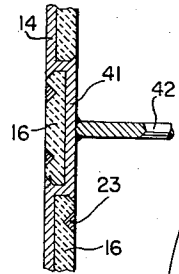

Fig. 5

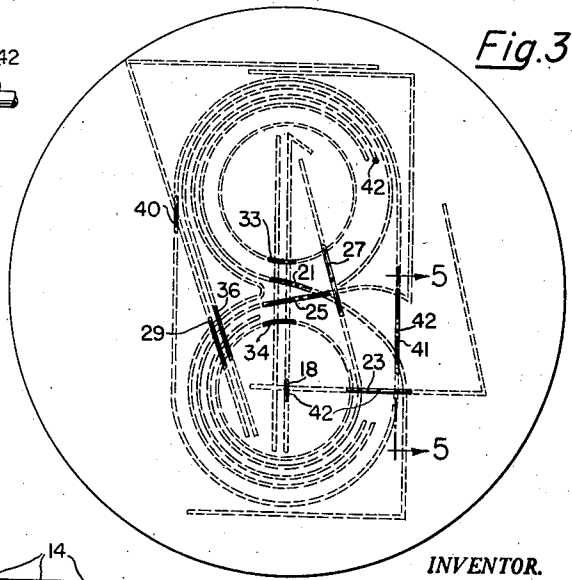

Fig. 3

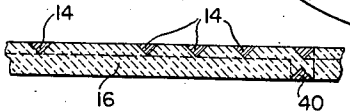

Fig. 6

INVENTOR.
ROBERT R. DRISCOLL

BY
Raymond B. Parker
ATTORNEY

1

2,833,949

GLOW INDICATING TUBE

Robert R. Driscoll, Philadelphia, Pa., assignor to Burroughs Corporation, Detroit, Mich., a corporation of Michigan

Application December 13, 1955, Serial No. 552,850

8 Claims. (Cl. 313-109.5)

The present invention relates to indicating devices and more particularly to glow lamp gas tubes for visibly showing any one of a plurality of numbers or other characters as predeterminedly selected.

Neon tube glow devices displaying an array of numerical characters are known to the art as exemplified by United States Letters Patent No. 2,142,106, issued to H. P. Boswau. In general, however, these tubes have been subject to manufacturing difficulties, have required large excitation potentials without affording reliable operation. The manner of assembling such tubes is both costly and unsatisfactory. Furthermore, such tubes are handicapped for precise viewing by the apparent displacement of the indicating member as seen from two different points.

An object of the invention is to provide a novel structural arrangement for the elements of a numerical display tube which is adapted for ready manufacture.

Another object is to provide a sturdy reliable numerical display tube of superior electrical characteristics.

Another object is to provide a number assembly for a display tube wherein hiding of parts of a number by other numbers, as in prior display tubes, is reduced to a minimum so each number is clearly defined when it is lit.

A further object is to provide a display tube wherein the number cathodes are arranged in a common plane and located in close proximity to the viewing end of the tube.

A further object is to provide an indicating display tube wherein parallax conditions are eliminated.

A still further object is to provide a character display tube wherein a plurality of cathodes in the shape of characters are etched, pressed or otherwise formed in the same face of an insulating disc as a pattern to be viewed to read-out a lit character.

To provide other improvements as will hereinafter appear.

In the accompanying drawings Figure 1 is a perspective view of a number display tube embodying one form of the present invention;

Figure 1A is a front face view of the tube showing a modified anode construction;

Figure 2 is an enlarged front face view of one form of cathode pattern as formed upon its mounting disc;

Figure 3 is a view of the back face of the disc of Figure 2;

Figure 4 is an exploded view of the cathode disc showing one form of number configuration adaptable for illuminated segregation;

Figure 5 is a section view on line 5-5 of Figure 3; and

Figure 6 is a section view on line 6-6 of Figure 2.

Referring to the drawings, one form of the invention is shown assembled in an evacuated gas filled transparent envelope 10 having a vitreous base 11 through which a plurality of base prongs 12 project for respective inclusion in control and lamp circuits. As usual in such envelopes a vacuum seal is provided but is herein shown located

2

at the base 11 to permit unrestricted visual inspection of a number glow through the smooth plane end wall 13 of the envelope 10. The indicating lamp assembly housed in the envelope 10 includes a plurality of cathodes 14 and an anode 15 common to all of the cathodes. In the present instance there are ten cathodes 14 respectively shaped to form numbers "0" to "9," inclusive, as shown in Figure 4, all being operatively arranged in a pattern to cause any selected number to glow without interference from any other, by applying an igniting potential to that particular cathode. Furthermore, in the formation of the pattern all of the cathodes are laterally offset or spaced relative to one another as is evident in Figure 2 so that when seen from the viewing end of the tube, each is clearly visible without disturbing interference from any of the others.

For locating the cathode pattern assembly in the envelope 10 for best viewing purposes, namely, in internal close proximity to the transparent end wall 13, a mounting disc 16 is provided formed of relatively thin dielectric material, preferably ceramic. Into one flat face of the disc all of the character shaped cathodes 14 are cast, etched, pressed or otherwise suitably formed by using electrically conducting metal suitable for use in gas tubes. In this manner ten numerals, functioning as cathodes, are arranged in a common plane for viewing through the end wall of the envelope 10.

In order to prevent any cathode number from making contact with another cathode number at any cross-over point, such numbers are disjointed at these locations on the viewing face of the disc 16 without, however, interrupting the electrically conducting continuity of the disjointed number as will be explained. Thus at the break 17 in the numeral "1" the disc 16 has two through holes, which carry the metal, during the forming process, to provide a bridge 18 on the back of the disc 16 as shown in Figure 3 in order to straddle the cross-over of the numeral "4" and so maintain the conducting continuity of the numeral "1." Likewise at the break 20 in the numeral "2," the disc 16 has two through holes which carry the metal, during the forming process, to provide a bridge 21 on the back of the disc 16 to straddle the cross-over of the numerals "1" and "4." In a similar manner at the break 22 in the numeral "4," the disc has two through holes which carry the metal, during the process of manufacture, to form a bridge 23 on the back of the disc 16 which straddles the cross-over of the numerals "2," "0," "6" and "8" and so maintain the conducting continuity of the numeral "4." Likewise, at the break 24 in the numeral "5" the disc 16 has two through holes which carry the metal, during its fabricating process, to form a bridge 25 on the back of the disc 16 to straddle the cross-over of the numerals "2," "1" and "4," and so maintain the conducting continuity of the numeral "5." Similarly at the break 26 in the numeral "6," the disc 16 has two through holes which carry the metal, during the forming process, to provide a bridge 27 on the back of the disc 16 which straddles the cross-over of the numerals "8," "9," "5" and "2" and so maintain the conducting continuity of the numeral "6." Likewise at the break 28 in the numeral "7," the disc 16 has two through holes which carry the metal, during its fabricating process, to form a bridge 29 on the back of the disc 16 to straddle the cross-over of the numerals "3," "5," "6" and "8," and so maintain the conducting continuity of the numeral "7." In like manner at the breaks 31 and 32 in the numeral "8," the disc 16 has two through holes for each such break to carry the metal, during the forming process, to provide bridges 33 and 34 respectively straddling the cross-overs for the numbers "1" and "4," and so maintain the conducting continuity of the numeral "8." Likewise at the break 35 in the numeral "9" the disc 16 has two through

holes which carry the metal, during its process of fabrication, to form a bridge 36 straddling the cross-overs for the numerals "3," "5," "6" and "8" and so maintain the conducting continuity of the numeral "9." In a similar manner at the breaks 37 and 38 of the numeral "0," the disc 16 has two through holes for each such break to carry the metal, during its forming process, to provide bridges 40 and 41 respectively straddling the cross-overs for the numeral "7" and the numerals "2" and "5."

Figure 5 illustrates in enlarged scale the bridging portion 41 for the numeral "0" and the manner of its connection to the balance of the numeral and its straddling relative to the crossing portions of numerals "2" and "5." It is also evident in this figure that the bridging portions extend along the rearside of the disc 16 in insulated relation to the portions of the other numerals which it straddles.

The cathode numbers may be formed with their jogged bridging portions in different ways. A desirable method is to form the disc 16 of ceramic material and cast or otherwise form shallow valleys or grooves in the front face thereof exhibiting the number pattern shown in Figure 2 and cast or otherwise form the bridging valleys or grooves on the back face of the disc exhibited in full lines in Figure 3. Holes are drilled through the disc to connect the ends of the bridging grooves on the back face with the gap ends of the grooves on the front face. The disc thus configured with grooves is dipped in a molten bath of electrical conducting metal, such as copper, and the metal fills the grooves and the connecting holes through the disc in the manner shown in Figures 5 and 6. After the metal hardens the opposite faces of the disc may be smoothed to remove any roughness present and to provide the flush relation of metal to ceramic shown in Figures 5 and 6. In lieu of ceramic material the disc may be formed of other electrical insulating material, such as glass, and the grooves for receiving the wiring conductors may be etched in the opposite faces of the disc. A similar method would be to etch away copper clad films on the opposite faces of an insulating member to form the desired conducting paths and provide conducting elements through the member for electrically connecting the bridging portions on the back face thereof with the gapped ends of the characters on the front face thereof.

For selectively energizing the respective cathodes 14, each has a lead 42 bonded thereto and arranged normal to the plane of its cathode to pass preferably through the disc 16 for respective bonding to the proper projecting tube prongs for circuit operation and selection. The presence of the bridging portions of the characters on the rear side of the disc is taken advantage of for connecting the leads to their respective numerals. Figure 5 illustrates one such connection. Each lead 42 is arranged in staggered relation to the remaining leads 42 and thus extend spaced one from another parallel to the axis of the tube from the disc 16 to the tube base connections. Thus with each cathode having a single lead the assembly lends itself to simple construction and assembly.

The anode 15 for operative association with the pattern of cathodes 14 is shown in the form of a ring encircling the pattern in out of contact relation therewith but in such close proximity thereto as to ensure substantially equal glow from all of the cathodes 14. Preferably, as shown in Fig. 1-A, the anode 15 is etched on the surface of the disc 16, by the same process as use for the cathodes 14, and includes a lead 43 bonded thereto to extend through the disc 16 to terminate in a joint with the proper tube prong. This lead 43 is coated with insulation, preferably Alundum-Ludox mixture, for complete electrical isolation from the cathode leads 42. A modified assembly of the anode 15 is shown in Fig. 1 wherein the anode ring is separate from the disc 16 and has two leads 44 passing through the disc 16 as supports for the ring and terminating respectively in connections to two tube prongs. These leads 44 are also coated with

insulation and pass lengthwise of the tube parallel to and spaced from the leads 42. The leads 44 support the anode 15 in a plane parallel and in close proximity to the plane of the disc 16, with the center of the anode ring coincident with the axis of the tube. Also the internal diameter of the anode 15 is greater than the transverse dimension of the cathode pattern in order not to interfere with the endwise viewing of any of the pattern numerals.

It will now be apparent that a complete unitary cathode and anode assembly has been devised wherein the cathodes are arranged in a novel pattern on the face of an insulating disc with each cathode in the shape of a different numeral. Thus each cathode has a separate lead extending to the corresponding contact of switching circuit contacts, any one of which can be selected to energize a particular cathode number. In the present system a ten point switch will be used to connect the individual cathodes selectively to a source of voltage of correct polarity. Since all of the cathodes lie in a common plane transverse to the axis of the tube it is possible to locate the cathodes internally in close proximity to the viewing end wall of the tube whereby parallax conditions existing in prior glow tube assemblies are eliminated. Also, it will be noted that the outline of each cathode numeral, except for cross-overs, is so adequately spaced apart from others that each numeral is a complete, clear, individual entity when viewed from the end wall of the complete tube. While cross-overs are in the form of gaps, these are of such minor length as not to interfere with a complete representation of a character. For conducting purposes these cathode character gaps are ingeniously closed on the back of the disc by bridges straddling the respective gaps. Furthermore the single plane assembly of cathode characters eliminates any chance of disturbing reflections.

In the foregoing, as well as in the appended claims, it is to be understood that where the use of the word "Numeral" occurs it is to be taken as illustrative of the shape of the cathodes and is to be considered broadly as any of many characters which is desired to be read-out by a glow tube.

What is claimed is:

1. An indicating tube of the glow lamp type, comprising a gas filled transparent envelope, a plurality of cathodes formed respectively in the shape of individually complete characters, means mounting the major portion of said cathodes in a common plane in said envelope, dielectric material between said cathodes, an anode operatively associated with said cathodes to ionize the gas thereabout, and a single lead from each complete character cathode and said anode to the exterior of the envelope at least two of said cathodes having overlapping portions, the overlapping portion of one of said two cathodes being insulated from the other cathode and bridging said other cathode to maintain the electrical continuity of each cathode while at the same time maintaining both of said cathodes insulated from each other.

2. An indicating tube of the glow lamp type comprising a gas filled transparent envelope, a disc of dielectric material in said envelope, a plurality of cathodes etched into the same face of said disc to form a pattern of partly overlapping individually complete characters, means preventing electrical contact at the overlapping points while maintaining the continuity of the characters, an anode operatively associated with said cathodes to ionize the gas thereabout, and a single lead from each complete character cathode to the exterior of said envelope and a lead from said anode to the exterior of said envelope.

3. An indicating tube according to claim 2 wherein the anode is a ring etched into the disc and encircling the cathodes.

4. An indicating tube of the glow lamp type, comprising a gas filled transparent envelope, a disc of dielectric material in said envelope, a plurality of cathodes formed in the front face of said disc to form a pattern of in-

5

dividually complete characters with some cross-over points, certain of said characters having gaps at the cross-over points of others of said characters, conductors on the back face of said disc respectively bridging the areas back of said gaps, means conductively joining the ends of each conductor bridge through said disc with the gapped cathode, an anode operatively associated with said cathodes to ionize the gas thereabout, a single lead from each complete character cathode, and a lead from said anode to the exterior of said envelope.

5. An indicating tube according to claim 4 wherein the leads for the cathodes are connected to the bridging conductors thereof.

6. An indicating device comprising an envelope, a transparent window in said envelope, an insulating supporting disc within said envelope oriented substantially parallel to said window, said disc having two substantially plane parallel surfaces, a plurality of individual metallic electrodes in the shape of indicator characters adapted to be viewed lying in a common plane in one surface of said disc facing said window, a plurality of said electrodes having gaps in them in said one surface across which portions of others of said electrodes extend, metallic bridging elements in the other surface of said disc and extending through said disc and connected across the gaps in said plurality of electrodes whereby each of said electrodes is made electrically continuous while being electrically insulated from each of the other metallic electrodes, an auxiliary electrode within said envelope adapted to have a voltage applied between it and the other electrodes whereby said other electrodes are made visible, and an electrical lead extending from each of said bridging elements and said auxiliary electrode to the exterior of said envelope whereby electrical connections may be made thereto.

7. An indicating tube of the glow lamp type comprising a gas-filled envelope, a transparent window in said envelope, a disc of insulating material within said envelope and oriented substantially parallel to said window, said disc having two substantially plane parallel surfaces, a plurality of metallic electrodes in the shape of indicator characters adapted to be operated as glow cathodes lying

6

in a common plane and embedded in one of said surfaces of said disc, said one surface facing said window, a plurality of said electrodes having gaps in them across which portions of others of said metallic electrodes extend, metallic bridging elements in the other surface of said disc positioned directly behind and in line with corresponding gaps in said plurality of electrodes, said bridging elements being electrically connected to the corresponding electrodes in said one of said surfaces, each metallic electrode thereby being electrically continuous while being electrically insulated from the other metallic electrodes, an auxiliary electrode adapted to be operated as an anode within said envelope, and an electrical lead extending from each of said metallic electrodes to the exterior of said envelope.

8. An indicating tube of the glow lamp type comprising a gas-filled envelope, a transparent window in said envelope, a glass disc within said envelope and oriented substantially parallel to said window, said disc having two substantially plane parallel surfaces, a plurality of metallic electrodes in the shape of indicator characters adapted to be operated as glow cathodes lying in a common plane and embedded in one of said surfaces of said disc, said one surface facing said window, a plurality of said electrodes having gaps in them across which portions of others of said metallic electrodes extend, metallic bridging elements in the other surface of said disc position directly behind and in line with corresponding gaps in said plurality of electrodes, said bridging elements being electrically connected to the corresponding electrodes in said one of said surfaces, each metallic electrode thereby being rendered continuous while insulated from the other metallic electrodes, an auxiliary electrode adapted to be operated as an anode within said envelope, and an electrical lead extending from the bridging elements of each of said metallic electrodes to the exterior of said envelope.

References Cited in the file of this patent

UNITED STATES PATENTS

2,632,128 Hancock ----- Mar. 17, 1953