

July 24, 1956

F. B. MAYNARD

2,756,366

LUMINOUS DISCHARGE TUBE AND SYSTEM

Filed April 1, 1954

3 Sheets-Sheet 1

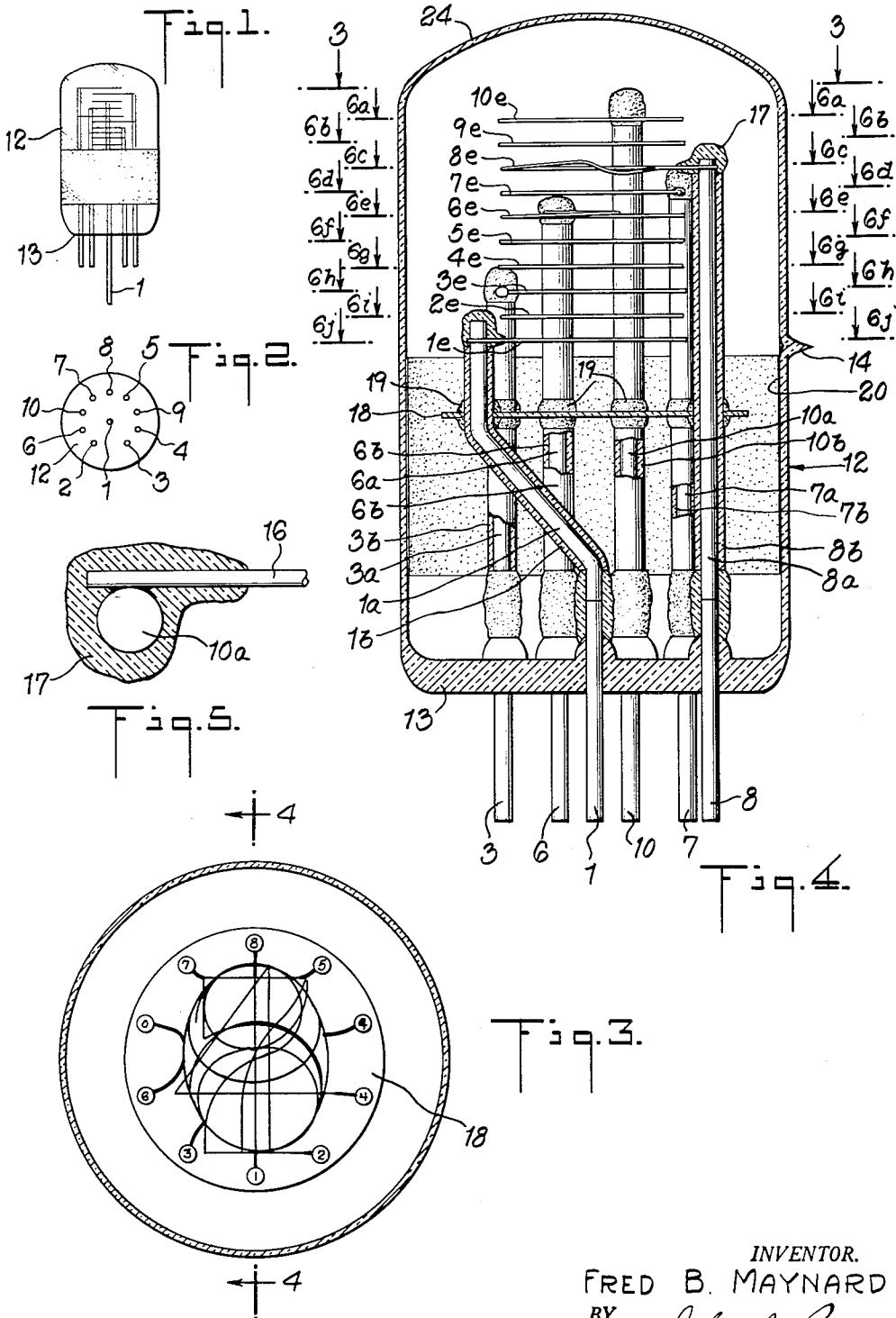

INVENTOR.  
FRED B. MAYNARD  
BY *John J. Rogan*  
ATTORNEY

July 24, 1956

F. B. MAYNARD

2,756,366

LUMINOUS DISCHARGE TUBE AND SYSTEM

Filed April 1, 1954

3 Sheets-Sheet 2

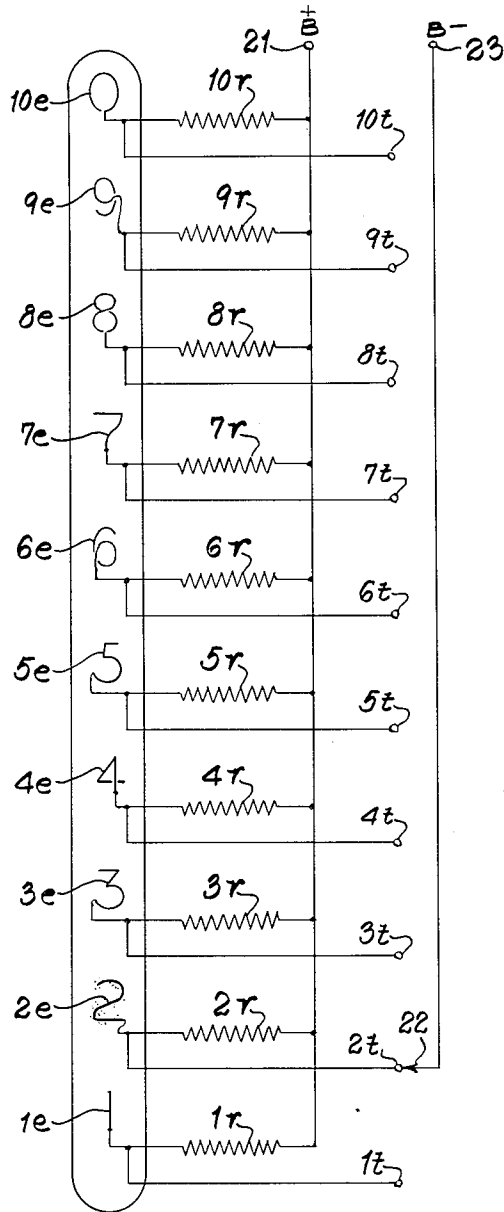
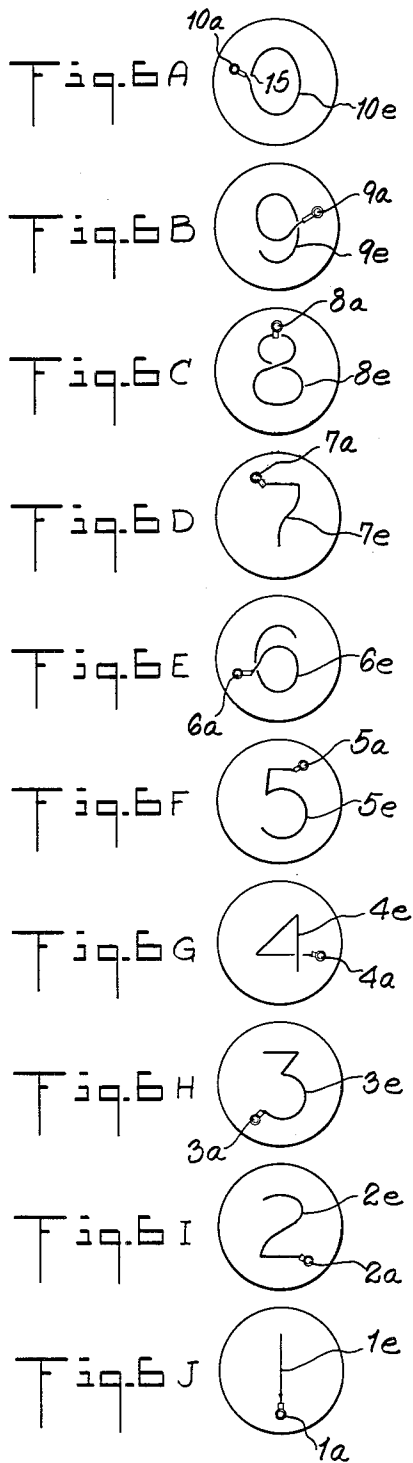

Fig. 2.

INVENTOR.  
FRED B. MAYNARD  
BY *John J. Rogan*  
ATTORNEY

July 24, 1956

F. B. MAYNARD

2,756,366

LUMINOUS DISCHARGE TUBE AND SYSTEM

Filed April 1, 1954

3 Sheets-Sheet 3

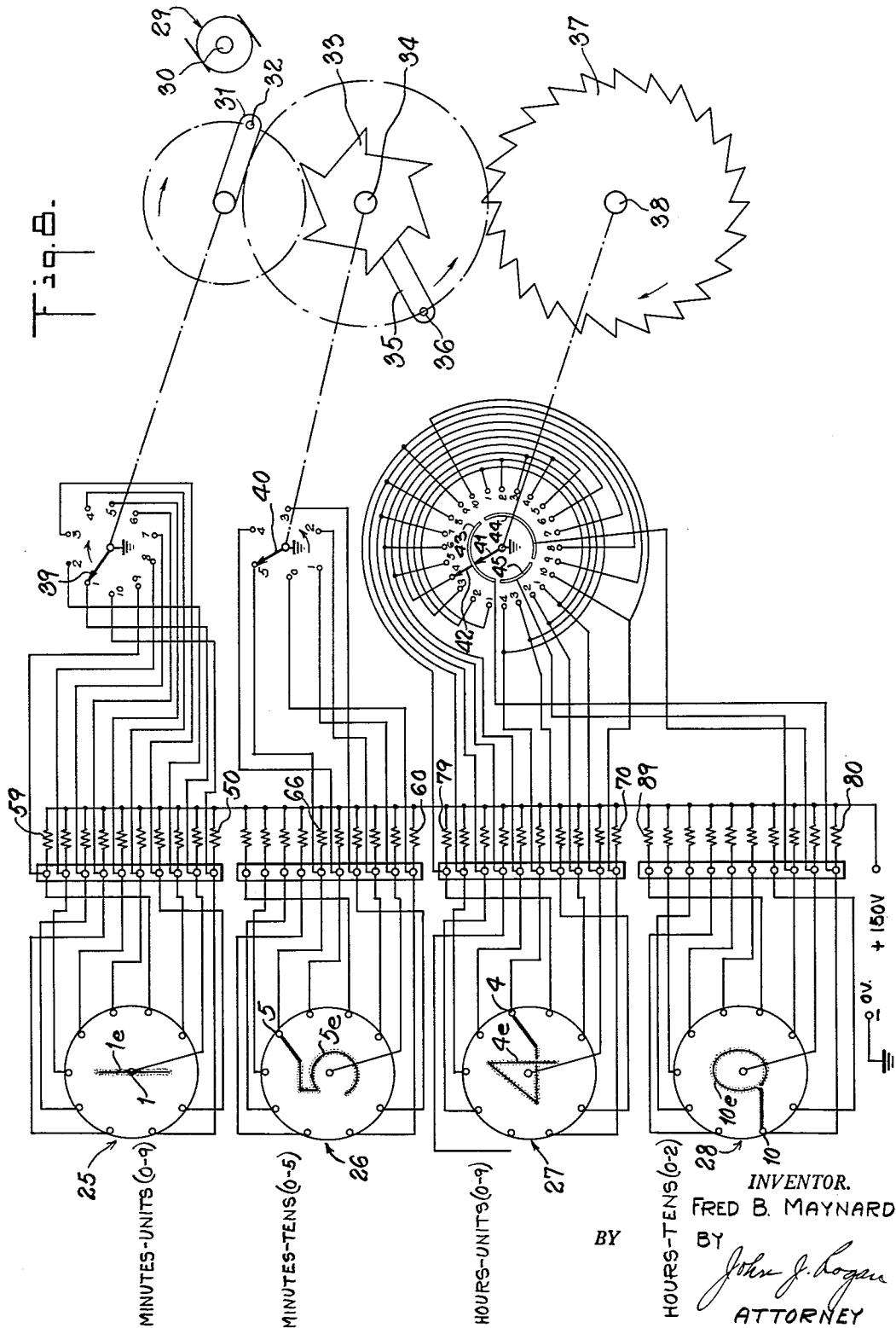

1

2,756,366

**LUMINOUS DISCHARGE TUBE AND SYSTEM** 5

Fred B. Maynard, Cedar Grove, N. J., assignor to National Union Electric Corporation, a corporation of Delaware

Application April 1, 1954, Serial No. 420,366 10

12 Claims. (Cl. 315—334)

This invention relates to luminous discharge tubes, and more especially it relates to such tubes wherein a plurality of separate luminous displays can be selectively produced.

A principal object of the invention is to provide a novel and simplified luminous display tube for producing different luminous displays within the same viewing boundary.

Various forms of luminous discharge tubes have been proposed heretofore, examples of which are the so-called counter tubes wherein a plurality of luminous targets are arranged in spaced side-by-side array. These targets are provided with a common electrode, and by means of a suitable switch, each target can be individually and selectively illuminated. One of the disadvantages of this conventional construction is that it is not possible to produce variable luminous displays within the same single boundary. For example, if the conventional device is to be used to display the numerals 1 to 10, then at any given confined boundary only a single numeral can be displayed. This necessarily follows from the fact that the individual luminous targets are arranged side-by-side. Therefore, in order to change the display, for example from numeral 1 to numeral 9, the visual display will not occupy the same position in front of the observer for each of these numerals.

Accordingly, it is another principal object of this invention to provide a novel luminous display tube wherein at any given viewing area or boundary, any desired luminous indicia, whether numerical, alphabetical, or other symbol, can be changed at will.

Another object is to provide a novel construction for a plural-indicia luminous display tube, wherein the luminous electrodes are in physically superposed or stacked array, whereby a series of such tubes can be arranged in columnar array so as to set up any desired intelligence message or visual display which can be changed at will.

A feature of the invention relates to a plural-indicia luminous discharge tube employing a series of fine-wire luminous targets in spaced stacked array, whereby any target in the stack can be selectively illuminated and viewed without any substantial obscuring by the remaining targets.

Another feature of the invention relates to a plural-indicia luminous discharge tube having a plurality of fine-wire targets mounted in superposed stacked array together with connections whereby any target can be selectively illuminated with cathode glow by causing the remaining targets to act as anodes. This arrangement avoids the necessity of using a separate common anode for all the cathode glow targets.

Another feature relates to an improved plural-indicia luminous discharge tube employing standard base constructions such as employed in conventional radio tubes and the like, and whereby any one of a series of luminous indicia may be displayed and viewed from one end of the tube within the same viewing area.

Another feature relates to the novel organization, arrangement, and relative location of parts which cooperate

2

to provide an improved plural-indicia luminous discharge tube. Other features and advantages not particularly enumerated will be apparent after a consideration of the following detailed descriptions and the appended claims.

In the drawing,

Fig. 1 is a vertical elevational view of a tube according to the invention;

Fig. 2 is a bottom view of Fig. 1;

Fig. 3 is a top plan view of Fig. 1 in enlarged form;

Fig. 4 is a sectional view of Fig. 3 taken along the line 4-4 thereof;

Fig. 5 is an enlarged detail view showing the manner of supporting each of the fine wire electrodes of Figs. 1 to 4;

Figs. 6A-6J are sectional views of Fig. 4 taken along the lines 6A-6A to 6J-6J respectively, and viewed in the direction of the arrows;

Fig. 7 is a schematic wiring diagram of the circuit arrangement for selectively energizing the electrodes of the tube of the preceding figures;

Fig. 8 is a schematic diagram of an automatic time display system using a multiplicity of the tubes according to the invention.

Referring to Figs. 1 to 5, the tube comprises an enclosing bulb or envelope 12 which is sealed in vacuum-tight manner to a header 13 and through which header are sealed a series of ten metal lead-ins or pins 1-10, nine of which are arranged in a circular array around the center of the header 13, the tenth pin is sealed through the center of header 13. Preferably, the spacing between successive circularly arranged pins is equal except for that between the pins 2 and 3. This arrangement of pins is standard in the well known nine pin base used in miniature radio tubes and the like. In addition to the nine pins, the additional or tenth pin is sealed in a vacuum tight manner through the center of the header 13, thus providing ten separate lead-ins for the respective ten cathode glow electrodes to be described. The bulb 12 may be of glass and may be evacuated and then filled with a suitable inert gas or mixture of inert gases through the exhaust tubulation 14 which can thereupon be tipped-off and sealed in the usual manner. The inert gas may be neon, argon, helium, or any mixture thereof at a predetermined pressure, for example 25 mm. of mercury.

Prior to sealing the bulb 12 to the header 13 there are welded to the internally projecting ends of the pins numbered 1 to 10 respective metal uprights or rods 1a-10a. Each of these rods is of progressively greater length. The rod 1a is bent, as shown in Fig. 4, so that the upper ends of all the rods 1a-10a are in a circular array. Telescoped over each rod is a corresponding ceramic sleeve 1b-10b. Preferably, each of these ceramic sleeves is somewhat shorter in length than the rod over which it is telescoped so as to provide an extending portion to which the corresponding one of each of ten wire electrodes is welded. These ten electrodes are respectively pre-bent to the shape of the desired symbol or indicia. Merely for purposes of illustration, it will be assumed that the device is to be used as a numerical indicator in which event each of the ten electrodes is bent to the shape of the corresponding numerals 1 to 0.

As shown more clearly in the sectional views of Figs. 6A-6J, each of the numerically shaped wire electrodes 1e-10e is in the form of an incomplete electrical loop. Thus, in the case of the electrode 10e, there is provided a minute gap 15 so that it appears visually as a substantially complete zero digit, but is still a non-inductive loop. Similarly, in the case of each of the electrodes 9e, 8e, 6e, and 4e, where the portion of the electrode wire is bent and crosses itself, at the crossing region there is a space so as to avoid the formation of a complete inductive loop.

As shown more clearly in Fig. 5, each of the wire electrodes has a radially extending portion 16 which is welded to that portion of its corresponding metal upright, and each wire electrode is so attached to its corresponding metal upright that it extends in a plane substantially perpendicular to the central longitudinal axis of the bulb 12. In other words, all the wire electrodes are located in spaced parallel planes considered along the said longitudinal axis. Fig. 3 shows the normal physical appearance of the device when viewed from the upper end of bulb 12 with no electrodes energized. Each of the wire electrodes 1e-10e is of sufficiently fine cross section that when any given electrode is energized and illuminated by its cathode glow its illuminated character is not to any substantial extent obscured by the intervening unenergized wire electrodes. For example, each of the electrodes 1e-10e may be made from tungsten wire of .005 inch cross section. However, tungsten wire, because of its springiness, is somewhat difficult to shape and preferably, therefore, each of the wire electrodes is formed from nickel wire of approximately .008 inch cross section.

In order to confine the cathode glow entirely to the indicia shape of each electrode, the portions of the wire which do not form an essential part of the desired indicia are coated with a suitable insulating ceramic cement, as indicated by the numeral 17. To preserve the circumferential spacing of the insulated uprights 1a-10a, these uprights with their ceramic sleeves 1b-10b pass through a circular metal disc 18 and this disc may be held in place on each upright by an insulating refractory or ceramic cement 19. Preferably, the upper face of disc 18 is oxidized or blackened in any suitable way so as to provide a sharp background contrast for each illuminated wire electrode. Preferably also the interior surface of the bulb 12 beneath the electrodes is provided with an opaque black coating 20, for example of graphite or other similar material.

I have found that by selectively applying a negative potential to any one of the above mentioned wire electrodes while maintaining the remaining electrodes connected to a positive potential, the desired electrode is illuminated with its respective cathode glow which is of sufficient intensity so that it stands out and is not obscured by any of the intervening unenergized electrodes. This effect is obtained because the cathode glow is a brilliant illumination and the diameter of the glow surrounding the associated wire is several times the diameter of the wire itself.

I have found also that this result can be achieved by connecting each electrode through respective one of a plurality of impedances or resistances 1r to 10r (Fig. 7), and thence to the positive terminal 21 of a suitable direct current source. Each of the resistors 1r-10r may be of the same value. Each of the electrodes 1e-10e is connected directly by a corresponding wire to a respective terminal 1t-10t of a suitable commutator switch whose movable brush 22 is connected to the negative terminal 23 of the direct current supply. As is well known in cathode glow devices, the electrode which is connected to the positive terminal of the power supply does not glow, but the electrode which is connected to the negative terminal glows of a cathodic glow which is a more or less close fitting sheath of evenly distributed illumination resulting from ionization of gas particles, and this illumination glow assumes very nearly an even thickness over the wire electrode area. Therefore, by selectively positioning the brush 22 I have found it possible to selectively illuminate any desired wire electrode.

From an examination of Fig. 7 it will be seen that, with brush 22 in contact with terminal 2t, electrodes 1e and 3e-10e are all held at positive voltage through their respective resistors 1r and 3r-10r. However, since the brush 22 is in contact with terminal 2t, the electrode 2e is connected to the negative potential terminal 23 so that

only the electrode 2e glows. The remaining electrodes, being at positive potential, the current flow produces sufficient voltage drop across their respective resistors so as to maintain the said remaining electrodes at positive potential. In other words, the particular selected electrode 2e assumes a negative potential with respect to all the remaining electrodes and it alone glows with a cathodic glow. However, by changing the position of brush 22, any desired one of the electrodes can be illuminated and, because of the fine wire character of the non-illuminated electrodes they do not to any substantial extent interfere with the effective illumination or glow visibility of the energized electrode.

It will be understood, of course, that the showing of Fig. 7 is essentially schematic and while the electrodes 1e-10e are shown in vertically displaced relation, actually these electrodes are in superposed parallel stacked planes, as shown in the physical view of Fig. 4. Therefore, the tube of Fig. 4 can be viewed through its upper end 24 in the direction of the arrows and for any given setting of switch brush 22 one electrode becomes visibly luminous.

While the device above described is capable of numerous applications for producing animated or other controlled movable displays, there is shown in Fig. 8 a system for using four of the devices as a time or clock display. In Fig. 8, there are represented by the numerals 25, 26, 27, 28, four devices each of which is identical with the device described above in connection with Figs. 1 to 5. Merely for simplicity in the drawing, only one electrode is shown in each of these devices. Thus, in device 25 only electrode 1e is shown and the devices 25-28 are assumed to be mounted so that their upper ends corresponding to end 24 (Fig. 4) are all viewable in end-on relation, namely perpendicular to the plane of the drawing sheet. In order to vary the multiple indicia display, there may be provided any suitable motor schematically designated in Fig. 8 by the numeral 29. This motor may be of any well known synchronous type such, for example, as a "Telechron" motor, conventionally used in electric clocks and whose shaft 30 rotates for example at the rate of six revolutions per hour. Shaft 30 carries an arm 31 having a pin 32 which is adapted to engage a six-toothed star wheel 33 affixed to shaft 38. Thus, shaft 30 rotates at six revolutions per hour, shaft 34 rotates at one revolution per hour, and shaft 38 rotates at  $\frac{1}{24}$  revolution per hour.

Shaft 30 is mechanically connected to a brush 39 which is adapted to wipe over ten stationary contacts each of which is connected through a respective resistor 50 to 59 and thence to the corresponding one of the ten lead-in pins of the device 25. The brush 39 is connected to the grounded negative terminal of the 150 volt direct current supply. Thus, in the particular position shown in Fig. 8, brush 39 applies negative potential to lead-in member 1 of device 25 alone and thus causes electrode 1e alone to be illuminated by cathode glow. The remaining electrodes in device 25 are unilluminated.

The shaft 34 is mechanically connected to a grounded brush 40 which is arranged to wipe over six stationary contacts. These six contacts are connected through respective resistors 60-66 and thence to respective lead-in members of the device 26. Since the device 26 is to represent the "tens" digit of the minutes, only six digits (that is, digit 0 to digit 5) are required for illumination in the device 26. Therefore, it is necessary only to energize the numerals representing digits 0 to 5 in device 26.

Likewise, the shaft 38 is mechanically connected to two grounded brushes 41, 42, which are adapted to rotate as a unit. Brush 41 is adapted to engage three stationary commutator segments 43, 44, 45. Brush 42 is adapted to wipe over twenty-four equally spaced stationary contacts at the ratio of one contact per hour. Ten of these contacts are included in the same arc subtended by commutator segment 43. The next ten stationary contacts are

included within the arc subtended by stationary contact 44. The next four stationary contacts are included within the same arc subtended by stationary commutator segment 45. Commutator segment 43 is connected to the tenth lead-in member of device 28 which is connected to electrode 10e of that device. In other words, so long as brush 42 is wiping over the first set of ten stationary contacts associated with segment 43, only the zero display will be produced on electrode 10e of device 28. The device 27 is arranged to indicate the units digits (that is, digits 0 to 9) of the hours, and the device 28 is arranged to indicate tens digits (digits 0 to 2) of the hours.

As the brush 42 steps one position per hour, and so long as brush 41 is in contact with segment 43, the corresponding units electrode of device 27 will be energized. Thus, in the particular setting shown in Fig. 8, brush 41 is in engagement with segment 43 causing the zero electrode of device 28 to be illuminated and the #4 electrode of device 27 to be illuminated. At the beginning of the eleventh hour, brush 41 engages segment 44 and illuminates the #1 electrode of device 28. At the same time brush 42 engages the #1 contact of this particular set and illuminates the #1 electrode in device 27. At the beginning of the twenty-first hour the brush 41 engages segment 45 to illuminate electrode #2 in device 28 and also to illuminate electrode #0 in device 27. The foregoing cycle of operations is repeated, thus continuously displaying the time on the four devices 25, 26, 27, and 28.

It will be understood, of course, that while one particular type of display system has been illustrated, the plural indicia devices can be used for any other visual display system such, for example, as train announcing systems, and the like. Furthermore, the invention is not limited to the provision of electrodes in the various devices in the form of numerals. For example, these electrodes in each device may be shaped to the form of letters of the alphabet, and by appropriate commutator means any desired intelligence or message may be instantaneously displayed. Furthermore, while the drawing illustrates the invention in a device having ten coaxially stacked skeleton wire electrodes in each device, it will be understood that a greater or less number may be employed depending upon the type of display system. Furthermore, it is not necessary that all the electrodes be of the same size. For example, electrode 1e may be in the form of a circle and another electrode may have its size shaped so that it fits within the boundary of the first electrode, in which event by suitable switching means one electrode can be maintained steadily illuminated and the other electrode within its boundary can be temporarily illuminated for various display purposes.

Various changes and modifications can be made in the disclosed embodiments without departing from the spirit and scope of the invention.

What is claimed is:

1. A plural-indicia gaseous glow discharge device, comprising an enclosing envelope containing an ionizable medium and having a transparent portion through which the indicia are viewed, a plurality of separate glow sustaining skeleton electrodes in spaced stacked array and in alignment with said portion of said envelope each of said electrodes being shaped to a distinctive indicia form, all the successive electrodes being spaced from each other and free from intervening light absorption or obstruction elements, and a plurality of lead-in members one for each electrode for selectively causing one electrode at a time to sustain a cathode glow which is substantially completely visible through the skeleton of the adjacent electrodes in the stack.

2. A plural-indicia gaseous glow discharge device, comprising an enclosing envelope containing an ionizable medium, said envelope having a viewing window, a plurality of separate skeleton electrodes each being a conductive member shaped to a distinctive indicia form and for sustaining a cathode glow discharge therealong, means to

support all said electrodes in substantial parallel stacked array and with all the electrodes in successive alignment with said window, and with the space between adjacent electrodes free from intervening light absorption or obstruction elements, and a plurality of lead-in members one for each of said targets for selectively causing one electrode to sustain a cathode glow which is substantially completely visible through the adjacent skeleton electrode.

3. A plural-indicia gaseous glow discharge device, comprising an enclosing envelope containing an ionizable inert gas, said envelope having a transparent portion to form a viewing window, a plurality of separate electrodes each in the form of a conductive member bent to a distinctive indicia shape for sustaining a glow discharge therealong, means to support said electrodes in successive substantially parallel spaced planes with all the electrodes in viewing alignment with each other and with said window, each of said electrodes having a narrow width facing said window whereby any electrode illuminated by a gaseous glow can be distinctively illuminated without substantial obscuration by the remaining electrodes, the successive electrodes being entirely free from intervening light absorption or obstruction elements.

4. A plural-indicia gaseous glow discharge device, comprising an enclosing envelope containing an ionizable inert gas, said envelope having a transparent portion to form a viewing window, a plurality of separate fine-wire glow sustaining electrodes, said plurality of electrodes each being bent to form a distinctive indicia, means to support said electrodes in spaced parallel stacked array, and a plurality of lead-in members equal in number to the number of said electrodes for selectively applying a negative potential to any desired electrode to illuminate said electrode alone by cathode glow.

5. A plural-indicia gaseous glow discharge device, comprising an enclosing envelope containing an ionizable inert gas, said envelope having a transparent portion forming a viewing window, a plurality of ten separate wire electrodes each adapted to sustain an individual cathode glow along its length, each of said wire electrodes being bent to the form of a distinctive indicia from 0 to 9 each of the indicia being free from any closed inductive loops, and a separate lead-in for each electrode for selectively applying a negative potential thereto to sustain a cathode glow along the length thereof.

6. A plural-indicia gaseous glow discharge device, comprising a glass bulb having a header at one end, a plurality of lead-in wires vacuum-tight sealed through said header, said bulb having a transparent portion forming a viewing window, a plurality of fine-wire cathode glow electrodes each of said electrodes being bent to form a distinctive indicia, and all of said electrodes being in optical viewing alignment with said window, and a plurality of metal uprights supported from said header and to which each of said electrodes is individually attached and with the planes of said electrodes being substantially parallel, successive electrodes being spaced from each other and with the said space free from any intervening light absorption or obstruction elements.

7. An indicator device of the kind described, comprising an enclosing bulb having a transparent viewing window at its upper end, a header closing off the lower end of said bulb and having a series of lead-in members sealed therethrough and spaced apart in a substantially circular array, said lead-in members each having a portion extending inwardly of the bulb and substantially parallel to the central longitudinal axis of the bulb, a plurality of wire electrodes each electrode being conductively attached to a corresponding one of said lead-in members and with the planes of said electrodes extending transverse to said longitudinal axis, all of said electrodes being in optical viewing alignment with each other and with said window, successive electrodes being spaced from each other and with the said space free from any intervening light absorption or obstruction elements.

8. An indicator device according to claim 7 in which portions of said lead-in members extend to respectively different heights within said bulb and substantially the entire length of each lead-in member within said bulb is provided with electrical insulation to confine the glow discharge entirely to the length of each wire electrode.

9. A plural-indicia gaseous glow indicator system, comprising in combination a gaseous glow device having an enclosing envelope containing an ionizable medium, a plurality of cathode glow electrodes within said envelope mounted in spaced stacked array, a window in said envelope in viewing alignment with all said electrodes, a source of potential having positive and negative terminals, a plurality of impedances one for each electrode, means connecting one end of each impedance to a respective one of said electrodes, means connecting the remaining ends of all said impedances in common to said positive terminal, and means for selectively connecting one of said electrodes substantially directly to said negative terminal for causing only said one of said electrodes to be illuminated by cathode glow.

10. A plural-indicia gaseous glow indicator system according to claim 9 in which each of said electrodes is in the form of a fine wire bent to distinctive indicia formation with the electrodes mounted successively behind each other and behind said window and each of said impedances is in the form of a resistor, and said selective connecting means includes a commutator having a movable contact element connected to said negative terminal and a series of stationary contacts each connected respectively and substantially directly to a corresponding one of said electrodes.

11. Plural-indicia indicator apparatus, comprising

means defining a viewing plane having adjacent boundary areas, a plurality of similar multiple indicia units each of the gaseous glow discharge type, each of said units comprising a series of skeleton electrodes arranged in stacked spaced array and each electrode formed to the shape of a respective indicia and arranged to have a cathode glow therealong which is substantially completely visible through the adjacent electrodes of the unit, successive spaced electrodes being free from any intervening light absorption or obstruction elements, each of said units being located in alignment with a corresponding one of said boundary areas, and circuit connections including commutator switches for said units for illuminating in any desired combination a single electrode in each of said units.

12. A plural-indicia gaseous glow discharge device, comprising an enclosing envelope containing an ionizable medium and having a transparent portion through which the indicia are viewed, at least three separate glow discharge sustaining skeleton electrodes in spaced stacked array and in alignment with said portion of said envelope, each of said electrodes being shaped to a distinctive indicia form, the successive electrodes being spaced from each other and free from any intervening light absorption or obstruction elements, and a plurality of lead-in members the total number of such lead-in members being equal to the total number of said electrodes.

#### References Cited in the file of this patent

#### UNITED STATES PATENTS

2,142,106	Boswau .....	Jan. 3, 1939
2,618,697	Metcalf .....	Nov. 18, 1952
2,618,760	Hancock et al. ....	Nov. 18, 1952