

Nov. 29, 1938.

H. PRESSLER ET AL  
ELECTRIC DISCHARGE LAMP

2,138,197

Filed Nov. 20, 1935

2 Sheets-Sheet 1

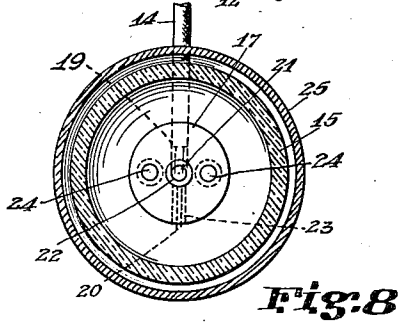
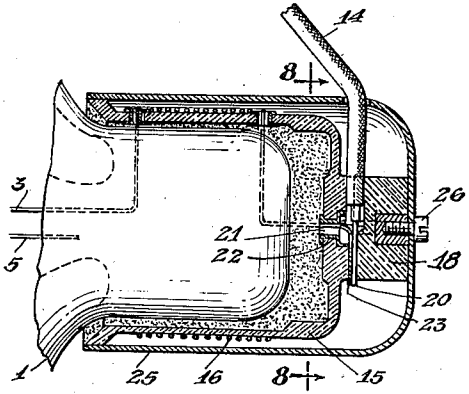
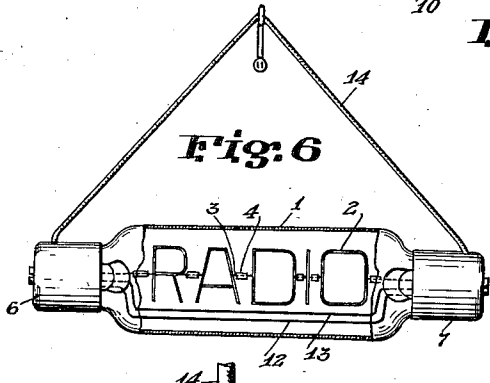
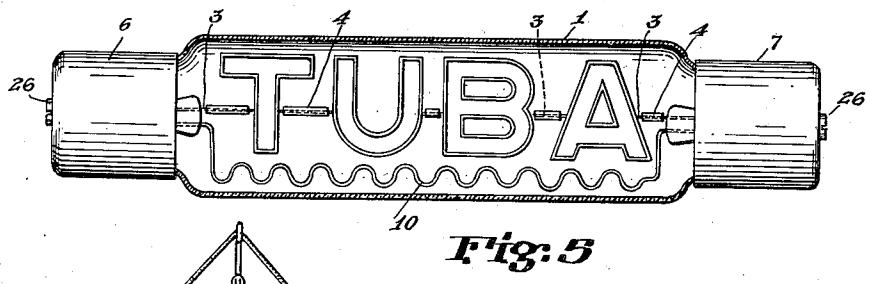
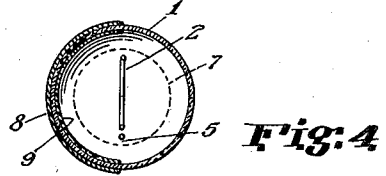
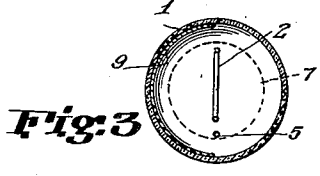
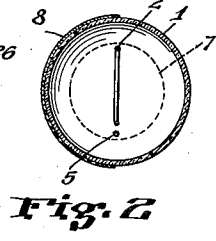
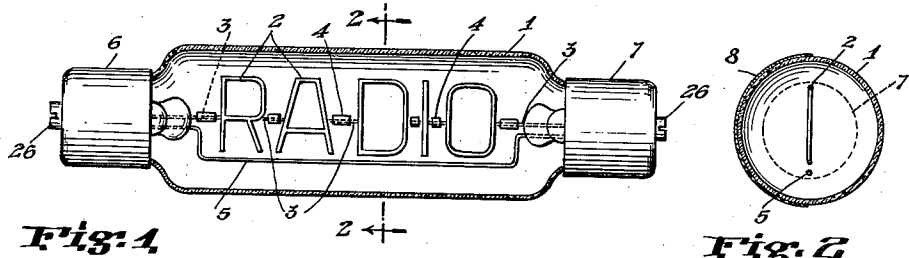

INVENTORS  
*Hermann Pressler*  
*Hans Richter*  
 BY *Karl Plon*  
 ATTORNEY.

Nov. 29, 1938.

H. PRESSLER ET AL  
ELECTRIC DISCHARGE LAMP

2,138,197

Filed Nov. 20, 1935

2 Sheets-Sheet 2

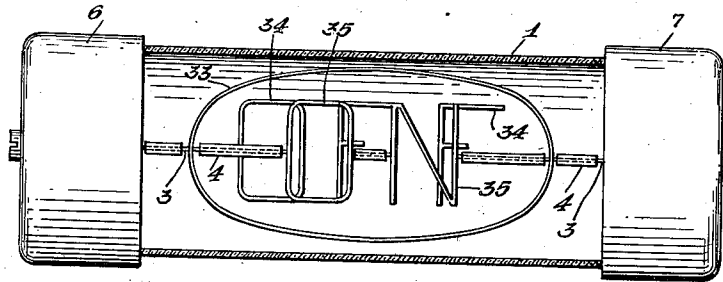
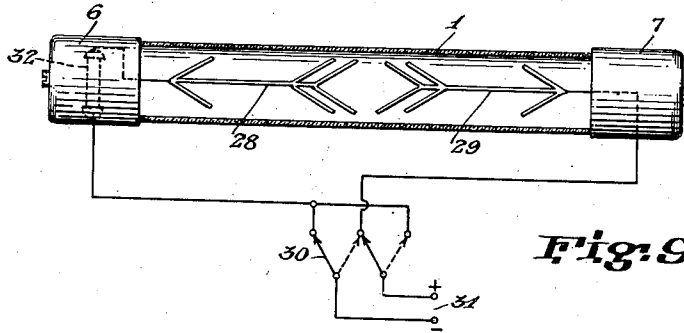

Fig. 10

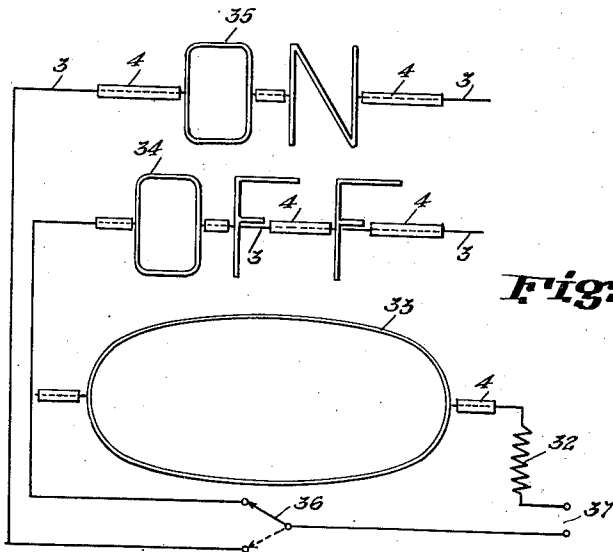

Fig. 11

INVENTORS  
Hermann Pressler  
Hans Richter  
BY  
Hans Richter  
ATTORNEY.

# UNITED STATES PATENT OFFICE

2,138,197

## ELECTRIC DISCHARGE LAMP

Hermann Pressler and Hans Richter, Leipzig, Germany, assignors to Radio Patents Corporation, New York, N. Y., a corporation of New York

Application November 20, 1935, Serial No. 50,640  
In Germany November 29, 1934

4 Claims. (Cl. 176—14)

Our invention relates to electric discharge lamps for advertising, decorative, signaling, or similar purposes, in which the cathode covered with a glowing layer is formed in the shape of the letters or other sign insignia in such a manner as to form a self-luminous sign appearing freely suspended within the discharge space.

In electric signs of the above mentioned type, it has become customary to provide a black coating upon the wall portions of the tube or lamp at the opposite side of the observer to prevent objects in the background from being visible through the lamp and interfering with the sign symbols or insignia whereby the letters or other insignia appear upon a black background. However, the decorative or advertising effect of discharge lamps of this type has been found to be rather poor and in addition a sign of this type produces a fatigue effect upon the eye on account of the extreme difference in brightness between the dark background and the luminous sign portions.

Accordingly, it is an object of our invention to provide a new sign discharge lamp of the type described which is free from the above mentioned disadvantages and which is capable of producing sign symbols or other insignia of both high brilliancy readily attracting the attention of the passers-by and having a pleasing and non-fatiguing effect upon the eye of the observer.

In its preferred embodiment the invention relates to electric discharge lamps of the type mentioned in which the electrodes consist of a wire bent in the form of the characters or other sign insignia and covered with a negative glowing layer during operation. Such lamps which in practical construction are preferably of cylindrical shape, are usually provided with a common support carrying a plurality of characters or other insignia and serving simultaneously as a lead for the electric supply current. The bent wire forming the sign proper is connected to a suitable electrode which during operation is connected to the negative pole of a current source, while a second suitably arranged electrode serving as the anode or cooperating electrode is connected with the positive pole of the source in such a manner that the advertising symbols or insignia become covered with a negative glowing layer in a manner well known. If alternating current is used, the second electrode will also be covered with a luminous layer as will be understood since in the latter case both electrodes are alternately at negative potential.

A further object of the invention is to provide a sign construction of the type described for op-

eration from an alternating current source in which the electrode provided in addition to the sign electrode does not interfere with the appearance of the sign characters or insignia.

Another object of the invention is the provision of a luminous sign discharge tube of the type described in which the second electrode forms a supplement to the characters or other sign insignia.

Another object of the invention is to provide a discharge lamp for display or decorative purposes which can be similarly operated by both alternating and direct current.

Another object of the invention is to provide a discharge lamp of the character described in which the luminous, glowing layer covering the sign characters or other insignia is substantially uniform and in which excess load and early disintegration of the electrodes is substantially eliminated.

Another object of the invention is to provide a discharge lamp of the type described, for advertising or similar purposes in which a plurality of signs or sets of sign characters or other insignia may be arranged in a single lamp for alternate or simultaneous operation.

The above and further objects and aspects of our invention will become more apparent from the following detailed description taken with reference to the accompanying drawings chosen for illustration of the invention.

In the drawings:

Fig. 1 illustrates in cross-section one form of a discharge lamp according to the invention.

Fig. 2 represents a cross-sectional view of a lamp according to Fig. 1 taken along line 2—2.

Figures 3 and 4 are cross-sectional views of modifications of a lamp corresponding to the view in Figure 2.

Figs. 5 and 6 illustrate modifications of a discharge lamp of the type shown by Fig. 1.

Figs. 7 and 8 are detailed front and side views, respectively, of a preferred construction of the end caps for a lamp as shown by Figs. 1, 5 and 6.

Fig. 9 illustrates a construction of a discharge lamp according to the invention embodying a plurality of sign insignia while Figs. 10 and 11 illustrate a further embodiment of a multiple or combined type of tube embodying a plurality of sets of sign characters or insignia arranged in a single envelope.

Similar reference numerals identify similar parts throughout the different views of the drawings.

With the aforementioned objects in view, the present invention relates to a discharge lamp of

the type described in which the sign or set of sign characters or other insignia is backed by a diffusely reflecting surface in such a manner as to appear upon a contrasting background. In accordance with one embodiment of the invention, an opal glass plate may be arranged a few millimeters behind the cathode or sign elements. Alternatively, a diffusely reflecting layer or surface may be applied directly to the portion of the tube walls behind the sign characters at the opposite side from the observer. This coating or layer may be applied either to the inner or outer wall of the tube. The application to the outer wall has advantages from the manufacturing point while the application to the inner wall has the advantage of preventing disturbing reflections from the glass wall of the tube. According to a further feature of the invention, a combination of both inner and outer coatings or layers may be provided, such as for instance by frosting of the inner wall surface and by providing the outer surface with a suitable reflecting coating. According to another alternative the lamp may consist to one half of its cross-section of a milky or opal glass or the like and of transparent glass to the other half of its cross-section. The latter construction can be easily realized in the case of tubes manufactured by a drawing process.

According to a further feature of the invention, a suitable coloring matter is applied to the reflecting coating or layer, preferably corresponding to the line spectrum of the discharge. In this manner extremely effective and decorative effects can be obtained. When using tubes with a neon filling it has been found that good results are obtained by means of a red colored diffuse reflecting layer.

Referring to Fig. 1 of the drawings, we have shown at 1, a glow discharge lamp of glass or any other suitable material enclosing a cathode wire 2 bent or otherwise shaped in the form of letters; representing in the example shown, the word "Radio", the individual letters being separated and supported by links or connecting bridges shown at 3. The latter are preferably coated with a suitable insulating material such as by means of glass sleeves 4 as shown, to prevent a glowing layer upon these portions. The anode or cooperating electrode is shown arranged underneath the sign letters in the form of a straight wire 5 at equi-distant spacing from the sign characters 2 and insuring substantially uniform current load on the individual letters, resulting in a substantially uniform luminous glow covering the entire sign. Items 6 and 7 represent the end caps of the tube housing the connecting terminals and serving as a mounting means for the tube. As is understood the electrodes and the supports thereof may be mounted or sealed in the tube walls in a manner well known in discharge tube manufacture.

Referring to Figs. 2 to 4, we have shown cross-sectional views of a tube described, illustrating the diffusely reflecting layer or surface forming one of the underlying subjects of the present invention. In accordance with the arrangement shown by Fig. 2, the portion of the tube at the opposite side from the observer is provided with a diffusely reflecting coating 8, preferably colored, in a suitable manner as described hereinbefore.

According to the embodiment shown by Fig. 3, a diffusely reflecting surface or coating 9 is supplied to the inner wall of the tube, such as by a frosting process while according to the embodiment shown by Fig. 4, both inner and outer coat-

ings are shown to be applied to the tube walls. Thus, for instance, in the latter case the inner wall may be frosted as shown at 9 and the outer wall coated with a reflecting layer 8 of milky or opal glass or any other suitably colored material, such as a cellulose lacquer or the like.

Referring to Fig. 5, we have shown a further embodiment of a discharge lamp according to the invention in which the sign is comprised of four letters shown at 2, mounted within the envelope or lamp 1 and carried by a common support shown at 3 serving simultaneously as a means for conducting the operating current. The supporting wire 3 is suitably covered with insulating sleeves shown at 4 so as to prevent a glowing layer from being produced upon these portions and interfering with the sign characters or insignia proper in a manner similar as shown by Fig. 1.

All the letters or sign insignia are shown to be connected to one electrode which in the case of direct current operation constitutes the cathode and during operation will be covered with a negative glowing layer in a well known manner.

According to another object and feature of this invention, the second electrode necessary to secure an electric discharge through the tube is constructed in the form of a frame or underscoring line or the like, acting as a supplement or addition to the advertising or decorative sign proper and preferably having a length greater than the largest dimension of the discharge lamp. In the embodiment shown in Fig. 5, the second electrode shown at 10 has the shape of a wavy line arranged underneath the set of advertising letters or other sign insignia. In this manner it is possible to operate the tube from alternating current without interfering with the appearance of the sign proper and with the additional advantage that the second electrode acts as a supplement to the sign proper in emphasizing and increasing the advertising or decorative effect thereof. The equi-distant arrangement of the second electrode 10 has the further effect of a substantially even current load on the separate sign characters, resulting in uniform luminosity and lack of excess load and consequent rapid disintegration of the electrode material.

In place of the wave-like shape of the second electrode, two or more parallel straight wires 12 and 13 may be arranged to serve as an underscoring line of the advertising letters, such as shown in Fig. 6. In either case the length of the individual wires should be designed in such a manner that the sum thereof is greater than the largest dimension of the tube. Experiments have shown that favorable results are insured if the length of the second electrode is about twice the largest dimension of the tube.

As will be understood, display or advertising tubes of the type described may be manufactured with very light weight, thus making it possible to suspend the tubes by means of the electric lead wires or connecting cord serving for applying the operating current to the electrodes. In the latter case, it is only necessary to provide an efficient connection insuring both efficient electrical contact without mechanical stress at the connecting joint. We have shown in Figs. 7 and 8 a preferred construction of the end caps 6 and 7 of the tube adapted to secure both efficient electrical contact and mechanical connection so as to make it possible to directly suspend the tube in position by means of a connecting wire or cord 14, as shown in Fig. 6. The end cap is composed of an inner cup-shaped portion 15 and an outer

portion or cover 25. The cap 15 carries a resistance winding 16, wound upon its outer cylindrical surface serving as a ballast resistance and connected with one electrode of the tube on the one hand and with the current lead or terminal on the other hand. The cap 15 at its outer end has a flat surface 17, upon which a disc 18 is mounted in any suitable manner, such as by means of screws shown at 24. We have furthermore shown a boring 19 between and in the direction of the contact surface of the disc 18 and the surface 17 having a smaller restricted portion as shown at 20. The cap 15 is furthermore provided with a central boring shown at 21 with a metal eyelet mounted therein provided with an extension or tongue 23. The latter is bent and passed through the narrow portion 23 of the boring 19 and placed in parallel and contacting engagement with the end of the connecting wire 14 from which the insulation has been removed. The adjacent thicker insulated portion of the connecting wire placed within the wider portion of the boring 19 is clamped between the surface 17 and the disc 18 by tightening the screws in such a manner as to secure both an electrically and mechanically efficient joint. The cap 15 is then covered by the outer protective cap 25 in a suitable manner such as by a screw-connection shown at 26.

Discharge lamps of the type described may be manufactured in a simple manner with two or more signs mounted in the same tube for either alternating or simultaneous operations, resulting in a substantial saving of cost both initial and manufacturing.

A construction of a multiple or combined sign tube of this type is shown in Fig. 9. In the latter, two arrow-shaped luminous electrodes 28 and 29 formed from a wire properly bent or otherwise shaped, are arranged within the tube or lamp 1. Item 30 represents a reversal switch. The electrodes 28 and 29 may be connected alternately between the positive and negative poles of a suitable direct current source indicated at 31 thru the switch 30 in such a manner that either one will be made a cathode and covered with a negative glowing layer. Item 32 represents a series or ballast resistance used to stabilize the operation of the tube in accordance with well known practice in the art similar to the resistance as shown at 16 Figure 7.

Referring to Figs. 10 and 11, we have shown a further embodiment of a combined advertising tube comprising two separate sign or sets of sign characters arranged within the same discharge space. In the example shown, the words "On" and "Off" shown at 35 and 34, in the form of wire-shaped electrodes suitably bent or otherwise shaped and connected are mounted one in front of the other within the tube. Item 33 represents a cooperating electrode formed in frame shape encircling the words forming the sign proper. The electrical circuit connection is shown more clearly in Fig. 11. The signs 34 and 35 and the frame 33 form three electrodes. The two words "Off" and "On" may be alternately connected and disconnected by means of the switch 36 so that either one of the electrodes 34 and 35 will be covered with a luminous glowing layer. Since the third electrode 33 has the shape of a frame, it will not interfere with the sign characters when alternating current is used for operation

but act as a supplement or emphasizing element of the sign characters proper.

As will be understood, instead of a manually operated switch, an automatic switch or flashing device may be provided well known in connection with intermittent or flashing advertising electric signs. In the latter case, preferably a thermo or bi-metallic switch is used which may be mounted within the discharge lamp in such a manner as to form a part of the electrodes and in which case the heat produced by the glowing layer serves as a means for controlling the bi-metallic or other thermoresponsive element.

It is evident from the above description that our invention as described with reference to the showing of the drawings, is to be regarded as illustrative rather than restrictive and that changes and modifications may be resorted to without departing from the spirit or scope of the claims appended hereto.

We claim:

1. A gaseous discharge tube comprising a transparent envelope containing an electrode shaped to form a display insignia, a gaseous atmosphere, and means for coacting with said electrode to cause a glow discharge thereof within the gaseous atmosphere to illuminate said display insignia, the rear inner wall of said envelope having light diffusing means to form a visible background for said display insignia and prevent multiple reflections of the illuminated display insignia by said envelope.

2. A gaseous discharge tube comprising a transparent envelope containing an electrode shaped to form a display insignia, a gaseous atmosphere, and means for coacting with said electrode to cause a glow discharge thereof within the gaseous atmosphere to illuminate said display insignia, the rear inner wall of said envelope being frosted for diffusing light from the discharge to form a visible background for said display insignia and prevent multiple reflections of the illuminated display insignia by said envelope.

3. A gaseous discharge tube comprising a transparent envelope containing an electrode shaped to form a display insignia, a gaseous atmosphere, and means for coacting with said electrode to cause a glow discharge thereof within the gaseous atmosphere to illuminate said display insignia, the rear inner wall of said envelope having light diffusing means and the rear outer wall being coated with a reflecting layer to form a visible background for said display insignia and prevent multiple reflections of the illuminated display insignia by said envelope.

4. A gaseous discharge tube comprising a transparent envelope containing an electrode shaped to form a display insignia, a gaseous atmosphere, and means for coacting with said electrode to cause a glow discharge thereof within the gaseous atmosphere to illuminate said display insignia, the rear inner wall of said envelope being frosted for diffusing light from the discharge and the outer wall containing a layer of opal glass to form a visible background for said display insignia and prevent multiple reflections of the illuminated display insignia by said envelope.

HERMANN PRESSLER.  
HANS RICHTER.