

THE WELDING OF ALUMINIUM MIG & TIG FUSION

POCKET GUIDE



Second Edition: 2004 © AFSA

Aluminium Welding - Bring Big Ideas to Life

Aluminium can be joined in many ways - a critical requirement in fabrication as whole products are usually formed from a number of parts. Joining methods include demountable systems such as bolting as well as more permanent methods including welding, especially where continuity of joining is required.

Aluminium welding is a discipline that can and needs to be learned. Correctly applied, fabricators find that an aluminium welded product is quicker to manufacture than the equivalent performing steel fabrication - and it offers a 40% mass advantage.

Aluminium welding opens opportunity in fabrication.

- The skill levels required for aluminium welding are higher but the number of hours per volume are significantly lower.
- While the hours required per ton for aluminium welding are higher, the metal is three times lighter than steel with the result that overall, aluminium fabrication is cheaper.
 - Aluminium fabrication uses commonly available tools.
 - Welded aluminium fabrications can be repaired.
 - The South African Institute of Welding has programmes to advance aluminium welding skills of welders, supervisors and welding engineers.

Introduction

Aluminium and its alloys are routinely welded and brazed in industry by a variety of methods. As expected they present their own requirements for the welded joint to be a success. Welding aluminium alloys is not more difficult or complicated than welding steel - it is just different and requires specific training. Aluminium and its alloys are easy to weld, but their welding characteristics need to be understood and the proper procedures employed.

*** This booklet examines the special needs for fusion welding of aluminium and its alloys - using the most common, modern methods plus providing practical hints, tips and traps to ensure successful joints.**

It is assumed that welding personnel have had previous exposure to the TIG / GTAW and MIG / GMAW processes through use with steel applications - so the hints and advice herein are specific to Aluminium.

It is not possible in a booklet of this size to give exhaustive technical information - such detailed information is available in several other publications from AFSA such as:

- Aluminium Welding Guide
- Introduction to Aluminium
- Aluminium Design Guide
- Aluminium Fabrication Guide

These and other publications cover brazing, soldering, resistance and other types of aluminium welding.

Copyright:

All rights reserved. No part of this publication may be reproduced or distributed in any form or by any means, or stored in a data base, or retrieval system without the prior written permission of the publishers.

Disclaimer:

To the best of our knowledge, the information in this book is accurate. AFSA assumes no responsibility whatsoever for errors in, or misinterpretation of, the information in this book or in its use.

1. The Welding of Aluminium

The most common commercial aluminium and aluminium alloy welding methods use an electric arc with either a continuously fed wire electrode [with DC current, with and without pulsed current] or a permanent tungsten electrode plus filler wire [with AC current]. The arc is protected by argon gas (or argon-helium gas mix) to shield the weld pool and the electrode from the surrounding atmosphere. Arc welding is easy to use, attains a high temperature, provides high heat input and is easy to regulate.

To ensure an acceptable weld quality, there are two basic factors to consider - breaking loose and removing the oxide film, and preventing the formation of new oxide during the weld process.

It is **essential** that proper preparations and precautions **always** be taken before welding commences. The surfaces to be joined and the area around the weld zone [~50 mm] must be degreased using a solvent [acetone or toluene] and a clean cloth. The area must be clean and completely dry as grease and moisture can form gases and cause pores in the welded joint. The metal surface must be lightly mechanically brushed in and around the weld, after degreasing, to remove surface oxides and to avoid oxide inclusion in the weld. Use a brush reserved for aluminium use only and kept free of oil contamination. The high melting- temperature [~2000°C] surface oxides must be removed just prior to welding (at least within three hours or less).

Welding must **not** be done in draughty areas as draughts can easily reduce the inert gas protection and interrupt the arc, resulting in a sub-standard weld. The weld must be properly shielded with the inert gas at the correct flow rate, and of the required purity, and nozzle distances must not vary from the weld point.

* More information on successful welding techniques is given later in this book.

Notes about Aluminium:

- Aluminium is alloyed with a range of other metals to change its properties to suit specific applications. Aluminium is light weight [about one-third the weight of steel].
- Aluminium has high thermal conductivity [3 to 5 times that of steel] which means heat is easily conducted away from the welding area. It is essential that the heat source is powerful enough to rapidly reach aluminium's low melting point of 565 / 650°C. Welding hot and fast usually gives the best results. Heavy sections are best preheated to reduce the effect of rapid heat loss.
- Aluminium's coefficient of thermal expansion is high [twice that of steel] - so it is prone to distortion and stress inducement if the proper welding procedure is not followed.
- Aluminium does not change colour when heated. Be careful!
- Aluminium is a reactive metal that quickly forms a surface oxide layer.
- Aluminium suffers a reduction in strength in the weld area [unlike steel]. When stressed, a welded aluminium structure will incur local deformation in the welded area first.
- Welding aluminium alloys demands very clean working practice as they are prone to contamination. [Tools such as brushes or mill wheels used on steel or other metals must not be used on it.].

2. The Aluminium Alloys

Aluminium is not just a single material, but a family of a variety of alloys grouped according to the alloy elements added and that provide the best combination of properties for a particular application. Alloy requirements may include strength, corrosion resistance enhancement, ductility, ease of welding, formability or combinations of some of these properties.

The alloys are described by a four digit numbering system:

1xxx Series: Pure aluminium (> 99,5% Al) with only trace elements. This material is soft with low mechanical strength, but high

conductivity. Used mainly in packaging and electrical applications [e.g. cables and bus bars]. Common alloys are 1050, 1070, 1100, 1200 and 1350. Welding filler metal is usually chosen to match the high purity so AWS ER 1050 or ER 1100 is commonly used though AWS ER 4043 is sometimes specified.

2xxx Series: Contains copper additions up to 6%, which allows hardening by heat treatment. Developed as a high strength alloy typically used for aircraft components, it can only be welded if the copper content is below 1%. The most common alloys are 2011, 2014, 2017 and 2024 and are rarely welded.

3xxx Series: Contains manganese additions of up to 1,5%. Used for roof sheeting, vehicle panelling and general sheet metal work. Commonly used alloys are 3003, 3004 and 3103. Welding filler material normally used is AWS ER 4043.

4xxx Series: Contains silicon up to 13% and widely used in casting and filler materials. Common casting alloys are A413/CEN 47100/LM 20, and A380/LM 24, CEN 44100/LM6, and A357/CEN 42100/LM25.

Filler metals normally used are AWS ER 4043 or ER 4047 being 6% and 12% silicon respectively. ER 4047 is commonly used for brazing aluminium alloys because of its low melting temperature.

5xxx Series: Contains up to 5% magnesium and widely used for engineering components, pressure vessels and transport equipment in road, rail and shipping applications. The common alloys are 5083, 5454 and 5251. Filler materials normally match the base material and can be of types AWS ER 5356, ER 5183 and ER 5554.

6xxx Series: Contain additions of silicon and manganese up to 1,7 % and 1,2% respectively. Used extensively for extruded sections of all shapes and sizes. Common alloys are 6063, 6082 and 6061. Filler materials normally used are AWS ER 4043 which give the highest degree of ease of welding, and ER 5356 which gives a better colour match where the welded assembly is to be anodised.

7xxx Series: Contains additions of zinc, magnesium and sometimes copper. Used typically for aircraft structures, military bridges, armoured vehicles and drilling rods where high strength to mass ratio is important alongside weldability. Alloys with less than 1% copper are weldable. Common alloys are 7017, 7020 and 7075. Filler material normally used is AWS ER 5356.

8xxx Series and 9xxx Series: Special alloys, rarely used in South Africa.

3. Welding Filler Material Selection:

One must consider what the most important characteristic is for a particular weld - and then carefully select the correct filler material accordingly. When welding dissimilar alloys such careful selection becomes even more important as the required strength, ductility, corrosion resistance, low temperature service capability or colour match for anodising may be the dominant factor in deciding which filler to use. **Table 1 on page 8** gives recommended filler materials for welding of alloys.

When a filler metal is used, the weld deposit alloy is a mixture of the filler metal and the base metal. The properties of this “new” alloy determine to some extent to properties of the joint - influenced by the degree of dilution of the weld metal by the base metal. Weld cracking is reduced by keeping base alloy dilution of the weld metal to a minimum.

4. Effects of Heat on Aluminium:

The different wrought aluminium alloy families **are split into two groups**: Non-heat treatable and heat treatable.

Unless the base metal is in the annealed or as-cast condition, fusion welding decreases the strength of both heat and non-heat treatable alloys.

Table 1. Filler Material Selection for Various Wrought and

Base metal To Base metal	1070A 1145 1200 1350 3003 3103	3004 3105	5052 5042 5251	5083 5182
1070A 1145 1200 1350 3003 3103	1100 (b)	4043 (d)	4043 (d)	5356 (b) (d)
3105 3004		4043 (d)	4043 (d)	5356 (d)
5251 5042 5052			5356 (a) (b)	5356 (d)
5182 5083				5183 (d)
5454				
6005 6060 6063 6070 6082 6101A 6261 6463				
7017 7005 7020				
EN 43 100 EN 44 100 EN 42 000 EN 42 100				

Notes to Table 1:

- The filler metal shown for each combination of base metals is the one most commonly used. However, the specific filler metal selected depends upon usage and type of joint and, in a number of cases, acceptable alternatives are recommended (footnotes 'a' to 'd' below).
- Filler metals conform to the requirements of AWS Specification A5.10-80.
- Exposure to certain chemicals or sustained temperature (over 65 °C) may limit choice of filler alloys. Filler alloys 5183, 5356 and 5556 should not be used in sustained elevated-temperature service.
 - 5183, 5356, 5554, 5556 and 5654 may be used. In some cases they provide:

Casting Alloys

5454	6005 6063 6082 6261	6060 6070 6101A 6463	7017 7020 7005	EN 42000 EN 42100 EN 43100 EN 44100
4043 (d)		4043	5356 (b) (d)	4043
5356 (a)		4043 (d)	5356 (b) (d)	4043
5356 (a)		5356 (a) (b)	5356 (a)	4043 (a)
5356 (d)		5356 (d)	5183 (d)	5356 (b) (d)
5554 (b) (d)		5356 (a) (b)	5356 (a)	4043 (a)
		4043 (a)	5356 (a) (b)	4043 (a)
			5356 (a)	4043 (a)
				4043 (c)

(i) Improved colour match after anodising,
(ii) higher weld ductility, and
(iii) higher weld strength. 5554 is suitable for elevated temperature service. Castings welded with these filler metals should not be subjected to post-weld artificial ageing.

[b] 4043 may be used for some applications. Commonly used in welding cast alloys.

[c] Filler metal with the same analysis as the base metal is sometimes used.

[d] 5186, 5356 or 5556 may be used.

Non-heat treatable alloys in the 1xxx, 3xxx and 5xxx series go through cold working processes in the mill, in order to increase mechanical strength. The degree of cold work is termed strain hardening and is designated by "H", after the alloy description, normally followed by two digits indicating the specific operations performed to achieve the condition and the degree of strain hardening achieved. The heat produced during welding will cause the material to return towards its original condition before it was cold worked. Therefore one tries to control the area of heat affected zone by using stringer weld beads and sequencing the welding to keep the material as cool as possible. If excessive heat input is used because of weaving or very wide weld beads and the metal is not allowed to cool down, the heat-affected zone (HAZ) will become excessively wide and so possibly weaken the joint.

Heat treatable alloys in the 2xxx, 6xxx and 7xxx series acquire strength through heat treatment. The process is designated by the letter 'T' after the alloy description and the 'T' is followed by a digit, which indicates the specific process (e.g. 'T6'). The additional heat produced during welding will, in effect, give the material additional heat treatment often resulting in an over aged condition with a coarse structure in the heat-affected zone. This is detrimental to the alloy strength.

To minimize this heat effect it is necessary to weld with low heat input and to ensure that the material does not remain at a high temperature for too long. This is achieved by planning the welding sequence so as to weld on cold material at all times. Where such a welding sequence is specified it is vital that the sequence of welds be adhered to.

5. Welding Processes for Aluminium

A variety of welding processes can be used to join aluminium including the fusion methods GMAW (standard MIG, plasma and pulse) and GTAW (standard TIG and plasma) giving high quality, all-position welding, manual, mechanised or fully automatic. Also resistance, MMA (metal arc, stick) and advanced processes such as solid state and friction stir welding. Choice of process is based on technical and/or economic reasons.

For most structural economical and quality welds, TIG and MIG are recommended for aluminium.

TIG welding is generally preferred for light gauge work up to 6 mm and for pipe work and intricate assemblies where excellent control over weld appearance and penetration is possible. Thicker material can be welded using TIG, but the very high currents needed, together with the very slow welding speeds required, render the process uneconomic for thick materials (> 12,5 mm). Butt, fillet, lap and edge welds can be carried out using TIG welding.

MIG welding is preferred for thicker sections [to over 75 mm] and where high productivity is needed for economic reasons. MIG welding can deposit up to about 4,5 kg per hour with weld travel speeds of 500 to 1000 mm per minute. Drawbacks of the MIG welding process are that control of penetration is difficult and edge welds are not possible. Pipe welding using MIG welding is not common because of the poor penetration control. Butt, fillet and lap joints are the most common configurations for MIG welding. Joint preparation is needed for thickness above typically 6 mm.

MIG advantages over TIG are greater penetration depths, narrower HAZs and one-handed semi-automatic welding. MIG weld joint quality compared to TIG welding gives better strength, penetration (especially into the root of fillet welds), corrosion resistance, durability and finish appearance and less distortion. MIG welding is easier to learn than TIG. TIG welding is preferred for repair welding of

castings, but MIG is preferred when welding castings to sheet and plate and extrusions [fabrication].

MIG welding speeds are about twice that of TIG, and higher for thick section welding. High speeds result in fast cooling of the weld area, which minimises distortion. High speeds and fast cooling of the weld area prevent mechanical properties of the joint from being reduced as much as they are by slower welding. Speed means corrosion resistance of the base metal in the HAZ is not reduced as much by MIG as by TIG. When TIG welding, the operator is limited to the length of weld that can be made by the length of filler wire - usually not more than 25 cm - without breaking the arc. With MIG and the filler wire being added automatically, welds of 60 cm are possible without breaking the arc. This results in fewer weld craters and more cm of weld per hour. TIG manual filler addition means the welder has complete control of the weld puddle at all times - a definite advantage, and especially in butt welding of small and medium angles and other shapes. This control is an advantage in welding of castings where variable material thickness is often encountered.

Good seam welds are essentially a result of optimally set welding parameters. Good TIG seams have a regular ripple finish and on both sides of the seam there is a narrow, white de-oxidised zone. The seam surface has a bright finish and is smooth and free of scaling deposits. Good MIG seams have a uniform fine ripple finish on the seam with an excellent transition to the basic material.

5.1. The Gas Metal Arc Welding (GMAW) or Metal Inert Gas (MIG) Process

MIG welding uses a standard DC constant voltage power source with a wire feed system and externally supplied inert shielding gas. Shielding gas for MIG welding aluminium is normally high purity argon or an argon helium mixture. The use of helium in the mixture increases the energy of the arc and is more suitable for welding thicker material. The welding current, arc length and electrode wire speed are controlled by the welding machine and, once adjusted for

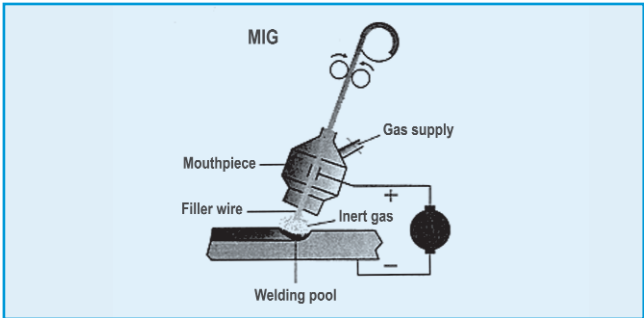

a welding procedure, do not require readjustment. The process is very adaptable to automatic welding.

The wire feed system can be of three types, each applicable to a particular type of work. The feeding of aluminium wire is automatic off a spool.

The **push type** of wire feeder has limited application since aluminium wire, particularly the high purity 1xxx grades, is soft and tends to bunch up in the drive rolls and liner. Such feeders are limited to a flexible conduit of about 3,5 m. For standard push type of feeder, 1,2 mm wire is used, and it is essential that the cable and torch assembly be kept as straight as possible - or alternatively that the cable be shortened to a maximum length of two metres. This clearly limits the equipment to bench work and small components. Thicker wire of 1,6 mm and the higher strength grades such as 4xxx and 5xxx series can often be fed successfully through a standard length torch cable provided a Teflon liner is used.

The combined push and pull system has one set of drive rolls in the wire feeder and a second set in the torch. The rolls are synchronised such that a small tension is maintained in the wire to prevent it bunching. This type of system can feed all wire diameters and all grades of aluminium up to 10 metres and is generally the

most favoured system for larger work pieces. This system uses the standard 300mm diameter wire spool that typically holds around 6kg of wire.

The spool on gun system uses a small spool of wire holding 0,5 kg mounted on the welding torch. With this system no wire feed unit is needed and the working distance from the power source is unlimited. Wire feeding is very reliable due to the very short feeding distance, but the spool-on-gun system has the drawbacks that the small spools of wire can cost more per kilogram than the large spools, and frequent spool changes are needed if a lot of welding is to be done.

It is recommended that specialist-supplier advice be sought when choosing gun and wire feeding systems.

Gun angle is very important when welding aluminium and needs to be kept as near to 90° to the workpiece as possible. Welding is carried out in the push direction only. Because of the high thermal conductivity of aluminium careful attention must be given to the avoidance of cold starts and crater cracks at the end of the welds. This can be done by reversing the direction of welding for about 25 mm at the start and end of the welds or by using a tungsten carbide burr to feather the ends of the welds. Use of run-on and run-off plates is another commonly used method of avoiding weld end cracks - it is important that these only be removed by grinding.

Applications of MIG Welding

The MIG process is best suited for larger sized components in materials of 2 mm and greater thickness. It is widely used for manufacture of engineering components, transport equipment, storage tanks, bus bars and pressure vessels. Generally the TIG process produces welds of superior appearance but MIG welds are generally stronger due to the lower heat inputs used, The MIG process can be used in all positions as long as the correct welding parameters are used. Modern developments in power source technology such as pulsed and synergic MIG processes allow

greater control of the welding arc so that better bead appearance, weld dimension control and improved mechanical properties can be obtained due to a reduction of the heat input.

Pulsed Arc MIG Welding - is based on conventional MIG welding with pulses superimposed on a low level constant background current. It is possible to obtain controlled spray transfer at an average current that is below the threshold value for the wire size being used. Metal transfer is actually controlled by the frequency and level of high pulses. Advantages with this method are:

- Use of thicker wire than with conventional MIG giving better, more secure wire feed and lower wire costs
- Less heat transfer to the parent metal that allows welding of thinner material (2 mm) and also results in less heat distortion problems
- Better weld contours and less spatter problems
- Uniform through-thickness welding is possible up to 5 mm material thickness without using backing for weld pool containment
- Better metal transfer when welding in difficult positions.

The equipment is more expensive than conventional MIG welding, but the advantages of the method often pay for the extra costs.

Trouble Shooting MIG Welding

Problem: Dirty weld bead, porosity

Usual causes: Plate not cleaned correctly or dirty filler wire. Welding wire not stored correctly and over oxidised. Inadequate cleaning action by arc. Unstable arc. Gas leaks in the hoses and connections. Spatter build-up in the nozzle distorting the gas flow. Torch angle and stand off distance incorrect. Shielding gas flow rate too low [refer to Table 2]. Condensation present due to the material

Table 2. Typical Semi-automatic MIG Procedures for Groove

Metal Thickness	Weld Position (Note 1)	Edge Preparation Diagram (Note 2)	Joint Spacing (mm) (Note 3)	Weld Passes (F = Forward) (R = Reverse)
1,6	F	A	None	1
1,6	F	G	2,4	1
2,4	F	A	None	1
2,4	F.V.H.O	G	3,2	1
3,2	F.V.H.A	A	0-2,4	1
3,2	F.V.H.O	G	4,8	1
4,8	F.V.H	B	0-1,6	1F. 1R
4,8	F.V.H	F	0-1,6	1
4,8	O	F	0-1,6	2F
4,8	F.V	H	2,4-4,8	2
4,8	H.O	H	4,8	3
6,3	F	B	0-2,4	1F . 1R
6,3	F	F	0-2,4	2
6,3	V.H	F	0-2,4	3F . 1R
6,3	O	F	0-2,4	3F . 1R
6,3	F.V	H	3,2-6,4	2-3
6,3	O	H	6,4	4-6
9,5	F	C-90°	0-2,4	1F . 1R
9,5	F	F	0-2,4	2F . 1R
9,5	V.H	F	0-2,4	3F . 1R
9,5	O	F	0-2,4	5F . 1R
9,5	F.V	H	6,4-9,5	4
9,5	O.H	H	9,5	8-10
19,0	F	C-60°	0-2,4	3F . 1R
19,0	F	F	0-3,2	4F . 1R
19,0	V.H.O	F	0-1,6	6F . 1R
19,0	F	E	0-1,6	3F . 3R
19,0	V.H.O	E	0-1,6	6F . 6R

Notes:

1. F=Flat; V = Vertical; H = Horizontal; O = Overhead.
2. See joint designs in Figure 1, diagrams A to K, pages 32 to 34.
3. Joint spacings and root faces should be accurately achieved using standard welding wire diameters (1.2, 1.6, 2.4 mm, etc.)

Welding Aluminium (From The Aluminium Association Welding Theory and Practice)

	Electrode Wire Diameter (mm)	Amps DC	Arc Voltage (Note 4)	Argon Gas Flow Rate (l / Min)	Arc Travel Speed (mm / sec)	Approximate Electrode Consumption (kg / 100m)
	0,8	70-100	15-20	12	10-19	3,2
	0,8	70-100	15-20	12	10-19	3,0
	0,8-1,2	90-150	18-22	14	10-19	2,7
	0,8	110-130	18-23	14	10-13	3,0
	0,8-1,2	120-150	20-24	14	10-13	3,0
	0,8-1,2	110-135	19-23	14	6-12	4,5
	0,8-1,2	130-175	22-26	16	10-13	6,0
	1,2	140-160	23-27	16	10-13	7,5
	1,2	140-175	23-27	28	10-13	7,5
	1,2-1,6	140-185	23-27	16	10-13	4,0
	1,6	130-175	23-27	28	10-15	15,0
	1,2-1,6	175-200	24-28	19	10-13	9,0
	1,2-1,6	165-185	24-29	19	10-13	12,0
	1,2	165-190	25-29	21	10-15	15,0
	1,2-1,6	180-200	25-29	28	10-13	15,0
	1,2-1,6	175-225	25-29	19	10-13	18,0
	1,2-1,6	170-200	25-29	28	11-17	18,0
	1,6	225-290	26-29	23	8-13	24,0
	1,6	210-275	26-29	23	10-15	27,0
	1,6	190-220	26-29	26	10-13	30,0
	1,6	200-250	26-29	38	11-17	30,0
	1,6	210-290	26-29	23	10-13	52,5
	1,6	190-260	26-29	38	11-17	75,0
	2,4	340-400	26-31	28	6-8	75,0
	2,4	325-375	26-31	28	7-8	105,0
	1,6	240-300	26-30	38	10-13	112,5
	1,6	270-330	26-30	28	7-10	105,0
	1,6	230-280	26-30	38	7-10	112,5

4. For 5xxx electrodes, use a welding current in the high side of the range and an arc voltage in the lower side of the range. 1xxx, 2xxx and 4xxx series electrodes will use the lower currents and higher arc voltages.

and wire being below ambient temperature / requiring preheating. Gas purity not adequate, less than 99,995% (N4.5) purity. Grinding disks used on a two-sided butt weld causing gross inclusions - use only tungsten carbide burrs for back chipping or beveling plate edges.

Problem: Arc length fluctuates. Burn backs

Usual causes: Disturbed wire feed. Maladjustment of filler wire spool brake and filler wire feed and wire straightener incorrect settings. Incorrect power source settings. Contact tip clearance is restricted or tip needs reaming. Teflon liner cut to incorrect length or blocked with shavings or oxide. Incorrect drive rollers used.

Problem: Lack of fusion. Faulty full penetration weld.

Usual causes: Oxide not properly removed from material or contact tip to work piece distance excessive. Welding current and voltage too low or wire diameter too large - refer to Table 2. Weld speed too high. Inadequate heat-up of welding location. Arc too long. Inadequate seam edge preparation.

Problem: Weld seam cracks.

Usual causes: Unsuitable filler, welding stresses excessive, and/or shrinkage obstruction.

5.2. The Gas Tungsten Arc Welding (GTAW) or Tungsten Inert Gas (TIG) Process

TIG welding is widely used for welding aluminium and it produces welds of good appearance and quality. A constant current AC power source with a continuous high frequency is used with a water or air-cooled TIG torch and an externally supplied inert shielding gas. The AC process is used to provide a degree of cleaning of the aluminium surface during the electrode positive cycle though this is not a substitute for proper cleaning of the base material. The tungsten electrode diameter is usually about 2,4 mm and the method can be used with or without filler metal. The filler material is fed into the weld bead from outside. TIG welding gives the welder very good control, but welding speed is normally slower than for MIG and requires higher welder competence.

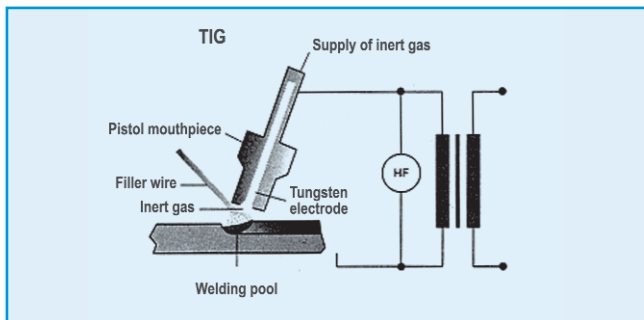

The choice of torch cooling depends upon welding parameters and duty cycle. They are usually water-cooled. Air-cooled torches can be used at up to about 100 amps. Zirconiated tungsten electrodes (which are preferred over the thoriated type), and of the correct diameter for the current, are used (see Table 3). The end of the electrode is prepared

by reducing the tip diameter to $\frac{2}{3}$ of the original diameter and then striking an arc on a piece of scrap material. This creates a ball on the end of the electrode. The ball must not be larger than $1\frac{1}{2}$ times the electrode diameter. A good indication that the electrode diameter is suitable for the welding current is to observe the ball diameter and the ease with which it forms. An electrode that is too small for the welding current will form an excessively large ball, whereas too large an electrode will not form a satisfactory ball at all.

The torch **must** be maintained at an angle of close to 90° to the workpiece surface and the filler material must enter the weld pool at an angle of typically 5° . As well as the workpiece being properly clean it is important that the filler rod is also clean. If the rod has been exposed to air for a long time it is advisable to clean it by pulling the rod through a 'Scotchbrite' type of abrasive pad or through stainless steel wool in order to remove the oxide layer.

Applications of TIG Welding

The TIG welding process is best suited for thin gauge materials up to about 6 mm thick, but preferably only up to 4mm for best economy. Thicker material can be TIG welded, but this would require many more weld passes and results in high heat inputs, leading to distortion and reduction in mechanical properties of the base metal. High quality welds with good appearance can be achieved due to the very high degree of control available - the heat input and filler additions are controlled separately. TIG welding can be carried out in all positions and the process is always preferred for tube and pipe work and small, thin components.

Trouble Shooting TIG Welding

Problem: Dirty weld bead. Porosity.

Usual causes: Plate and filler rod not cleaned correctly. Shielding gas purity is too low; use 99,995% (N4.5) purity minimum. Gas hoses or connections are leaking. Torch cooling water bypassing seals. Gas shield disturbed by draughts. Incorrect torch and filler rod angles. Tungsten electrode is off center. Ceramic nozzle is damaged [this does not wear out, but is easily cracked or broken]. Grinding disks used on a two-sided butt weld cause gross inclusions; use only tungsten carbide burrs for back chipping.

Problem: Tungsten inclusions.

Usual causes: Electrode touching weld pool. Undersized electrode for the welding current used. Excessive welding current. Contaminated electrode.

Problem: Weld seam cracks.

Usual causes: Unsuitable filler alloy wire, welding stresses excessive, shrinkage obstruction.

Problem: Faulty full penetration weld.

Usual causes: Wrong welding power, welding speed too high or too low, weld pool too hot or too cold, incorrect welding gap.

6. Guide to Welders

How to avoid pitfalls beyond your control

Before welding work is started check the following to ensure an adequate chance of success:

- **Fit up**

Aluminium is very intolerant of poor “fit up”. Joint gaps greater than 1,5 mm are difficult to fill in aluminium and will seriously compromise the life of the fabrication.

Table 3. Recommended Practices for Manual AC TIG Welding of

Plate Thickness (mm)	Welding Position (See Note 1)	Joint Type	Alternating Current (Amps)
1,6 1,6 1,6	F H, V O	Square butt Square butt Square butt	70-100 70-100 60-90
3,2 3,2 3,2	F H, V O	Square butt Square butt Square butt	125-160 115-150 115-150
6,4 6,4 6,4	F H, V O	60° Single bevel 60° Single bevel 100° Single bevel	225-275 200-240 210-260
9,5 9,5 9,5	F H, V O	60° Single bevel 60° Single bevel 100° Single bevel	325-400 250-320 275-350
12,5 12,5 12,5	F H, V O	60° Single bevel 60° Single bevel 100° Single bevel	375-450 250-320 275-340

Notes:

1. F = Flat; V = Vertical; H = Horizontal; O = Overhead
2. Diameters are for standard pure or zirconium tungsten electrodes. Thoriated tungsten electrodes are not generally used for AC TIG

Aluminium

Electrode Diameter (mm) (See Note 2)	Argon Gas Flow Rate (l / Min)	Filler Rod Diameter (mm)	Number of Passes
1,6	5	2,4	1
1,6	5	2,4	1
1,6	5	2,4	1
2,4	8	3,2	1
2,4	8	3,2	1
2,4	8	3,2	1
4,0	10	4,8	2
4,0	10	4,8	2
4,0	10	4,8	2
6,4	10	6,4	2
4,8	10	4,8	3
4,8	10	4,8	3
6,4	12	3	3
4,8	12	3	3
4,8	12	4	4

- **Alignment**

Welds are designed to carry a specific load and any additional load will shorten the life of the weld. Any radial or angular misalignment should be corrected before attempting to weld. Such additional loads can be the result of unpredicted loads such as bending because of poor joint alignment.

- **Humidity**

Molten aluminium has a high solubility for hydrogen, but on solidification the gas bubbles remain trapped in the weld as spherical porosity. This does not seriously affect the strength of the weld, but it considerably reduces the ductility. Joints should be fully protected from moisture. Where humidity cannot be avoided, such as in coastal conditions particularly during early morning, then a local preheat of typically 100 °C can be applied. The use of temperature indicating crayons is helpful to ensure that the correct temperature is attained. This preheat should be followed by normal cleaning procedures. Any preheat should be applied with caution since some alloys can suffer a serious loss of properties if too high a temperature is maintained for too long.

- **Wind**

The gas shield used in the MIG or TIG welding process is quite fragile and easily disturbed by wind. Whilst this is easily taken care of in the workshop it can become a serious problem in site work. Under windy conditions wind breaks must be erected around the welding area. Failure of the gas shield allows rapid oxidation of the weld pool, causing oxide inclusions.

- **Alloy weldability**

The welder should check before starting to weld that he has been supplied with the correct material. This applies to the filler wire or rods as well as to the material to be welded.

- **Equipment condition**

Before welding it is always good practice to check the equipment condition - not only for quality reasons but also to

ensure welder safety. Check the overall condition of the welding machine, the torch, nozzle and cable for any damage. The contact tip in a MIG torch wears surprisingly quickly and any play between the wire and the contact tip must be rectified by replacing the tip, otherwise the ability of the welding current to pass into the wire is seriously reduced. This leads to erratic feeding and reduced weld quality. The gas hose must be securely attached to the regulator and the welding machine or wire feeder, and must be free from obvious damage such as cracks or splits. The work cable must be free from damage and securely connected to the machine and the work clamp. It is impossible to produce quality welds without sound electrical connections all the way round the welding circuit.

- **Weld preparation**

Correct weld preparation is vital if quality welds are to be achieved. In most workshops the welder does not prepare his own joints, so he must always check that the weld preparation matches the drawing on the weld procedure. Attempting to weld without the correct weld preparation seriously compromises the chances of obtaining a good quality weld and such defective preparation must be rectified. Part of weld preparation is cleaning to remove any contamination from the area to be welded.

- **Weld significance (Criticality of specific welds)**

The welder should be familiar with the design of the fabrication in order to ascertain which, if any, of the welds are especially critical so that they can have the utmost care and attention devoted to them whilst others may tolerate a slightly less stringent approach to the work.

- **Welding plan and sequencing**

Attempting to weld without the correct welding procedure seriously reduces the possibility of obtaining a good quality job. It is essential that the welder adhere strictly to the given welding procedure, particularly with regard to the welding parameters of voltage, current, travel speed and welding sequence since

these have a great influence on the mechanical properties of the weld as well as on distortion.

- **Welding process**

It is vital that the welding process specified in the welding procedure is used to carry out the weld since some joint types and weld preparations are more suited to one particular welding process and it is very difficult to obtain good quality welds by the wrong process. If a welding machine breaks down then it must be repaired or replaced before the job can proceed; it is not acceptable to substitute for example a TIG machine with a MIG machine. Similarly, if the welding procedure calls for the weld to be carried out, for example, in the down-hand position and a crane is not available to turn the work piece then welding must be discontinued until the job can be turned. If preheat has been applied then this must be maintained during the delay, but welding must not be carried out in a position other than that called for by the defined welding procedure.

- **Check procedure is relevant**

The welding procedure provided to the welder must be the correct one for the job to be done otherwise he is guessing how to carry out the weld. Drawing numbers or job numbers as appropriate in the particular organisation must be correlated to ensure that the weld procedure is appropriate to the particular job.

- **Settings**

The welding machine must be capable of being set to the welding parameters needed for the job. This means that volt meters and current meters must be in good working order and calibrated to ensure accuracy and conformance with the welding procedure. In addition - an independent measuring device such as a clamp type multi-metre with ranges adequate for the welding process should be available for periodic checks of the welding machine metres - especially when the welding is carried out on a different machine to that on which the welding procedure was developed. Normally a welding procedure

specifies a small range of parameters and it is essential that the welder adhere to these.

- **Filler wire type, cleanliness**

The wire or filler rods must be the correct type for the job and be clean and free of contamination. Whilst MIG wire is generally supplied clean the spool should preferably be removed from the wire feeder at the end of the shift and placed in a clean plastic bag overnight. At the very least the wire should be covered overnight to keep it clean. MIG wire is best used within as short a period as possible after being opened as it, like the base material, forms an oxide layer and can therefore contribute to oxide inclusions in the weld. TIG filler rods should be kept in their original packing, often a plastic tube, until needed. If contamination is suspected, then the rods must be wiped with a clean cloth soaked in a solvent such as acetone, and then pulled through a 'Scotchbrite' or stainless steel wool pad.

- **Gas type, flow, suitability, purity, contamination**

The type of gas to be used is defined in the welding procedure and the welder must ensure that he is using the correct gas. Argon or argon-helium mixtures are usually used for welding aluminium and the heat of the arc and therefore the penetration of the weld depend on using the correct gas. A helium addition to the gas increases the arc energy, so substituting pure argon for this mixture would reduce the weld penetration particularly on thicker material and lead to defective welds. The required gas flow must be adhered to since too little gas results in a loss of shielding causing oxide inclusions. Too high a gas flow causes turbulence in the gas shield that entrains air and also causes oxide inclusions. A gas purity of 99.995% is needed and the welder must check when he is issued with a new cylinder that the label on the cylinder indicates suitable gas purity. Where gas impurity is suspected, it is possible that the welding equipment is actually contaminating the gas. When water cooled torches are being used, water leaks can occur allowing moisture to contaminate the gas and cause hydrogen porosity. Oil or

grease is never needed on gas fittings and if such contamination occurs then it must be thoroughly cleaned.

7. Distortion Control

For a given change in temperature aluminium expands or contracts about twice as much as steel and this can give rise to considerable distortion as a weld cools. Precautions therefore need to be taken to control this otherwise the welded structure may well be unusable. Typical types of distortion include longitudinal shrinkage, transverse shrinkage, angular distortion and bowing.

Following three basic rules when welding can minimise distortion.

Rule 1 - Reduce the effective shrinking force:

Do not over weld.

The use of excessive weld metal over and above that needed to meet the service requirements of the weld is not only wasteful but increases distortion. Ensure proper edge preparation and fit up. This will allow the minimum amount of weld metal to produce a strong joint.

Use few passes.

The use of many, small passes increases lateral distortion. Use of fewer passes with a large diameter electrode minimises lateral distortion.

Place welds near the neutral axis of the device.

This minimises the effective shrinkage force since the weld does not have sufficient leverage to pull the plates out of alignment.

Use intermittent welds.

This also reduces the amount of weld metal and can result in significant cost savings as well as minimising distortion.

Use back step welding technique to produce a continuous weld

This involves welding a number of overlapping beads with the general direction of welding being, say from right to left, but each individual bead being welded from left to right.

Rule 2 - Make shrinkage forces work to minimise distortion:

Locate parts out of position.

Pre-setting the parts such that the contracting weld metal pulls them into proper alignment when the weld cools is a common way of using the shrinkage of the weld metal to advantage.

Space the parts to allow for shrinkage.

Calculation backed up by experiments will indicate how much space needs to be left for parts to shrink into correct alignment when the weld cools.

Pre-bending components may be appropriate so that the contracting weld metal straightens them as it cools.

Rule 3 - Balance shrinkage forces with other forces / with another:

This can often be achieved by adhering to a welding sequence, which places weld metal at different points around the structure so that the shrinkage of one weld counteracts the distortion caused by a previous weld. Peening the weld bead as it cools stretches the weld, thus counteracting its tendency to contract and shrink as it cools. Use jigs and fixtures - the most common method of distortion control, it relies on clamping the work firmly so that the weld is forced to stretch as it cools.

8. MMA (Manual Metal Arc) Welding of Aluminium

MMA welding of aluminium is possible, but not generally used in manufacturing. It is most often used for repair welding of cast components where a once off' repair is needed and TIG equipment is not available. Most electrode suppliers have a limited range of aluminium electrodes, often only one type which is usually a 4xxx series alloy since the electrode is usually used to repair a casting. The process requires a DC constant current power source with an open circuit voltage greater than 60 volts. The electrode produces an acrid fume so it must be used in an area with good ventilation. The glassy slag often requires mechanical removal followed by hot water rinsing to remove the last residues.

9. Brazing of Aluminium

Many aluminium alloys can be successfully brazed using filler metal with a melting temperature below that of the base metal but above 450°C. The oxide layer on the surface of the aluminium is removed by a flux and then the filler metal flows into the joint by capillary action. In order for this action to take place the joint gap is maintained below 0,5 mm. A typical application for aluminium brazing is in the manufacture of automotive radiators. The filler metal is invariably the aluminium-silicon 4xxx series, particularly 4047. Because of the highly reactive nature of the flux, its residues must be completely removed after brazing, usually by mechanical methods followed by washing in hot water.

10. Codes of Manufacture

There are many situations where welds play a significant role in the safe use of a component or where the weld quality will strongly influence the life of a fabrication. It is recommended that a code of manufacture is adopted to ensure that all aspects of design, material specification, fabrication, welding and inspection are clearly addressed. These codes would include those related to design criteria, quality systems, welding procedure and welder qualification and non-destructive testing. Typical codes may include AWS D1.2, ASME B96.1 and BS 8118, which are specific to aluminium. Other applicable codes would be BS EN 719 which deals with welding coordination. ISO 3834 deals with quality requirements from basic requirements to stringent requirements.

11. Other Considerations

Experience in the field has shown that aluminium welds can fail in service.

In order to reduce these failures the following points should be considered:

- Can the weld be eliminated by using designs that incorporate extrusions or plate sizes that reduce the number of welds?
- Areas subject to fatigue in a fabrication need to be considered with a view to the weld acting as a stress raiser. Weld reinforcements in these areas may need to be ground flush and polished to reduce this effect. Fillet welds, particularly in high stress areas must be dimensionally correct, preferably concave. The weld requirements as detailed in the welding procedure must be adhered to. Weld stop-starts should be minimised.
- Weld quality monitoring is most important. Welding is termed a special process and a quality management system will require that the welding parameters be recorded on a welding record to ensure compliance with the welding procedure specification. Whilst it is not normally necessary to re-qualify welders who are carrying out the same job regularly, certain contracts may need the welder to produce a test piece for testing and qualification.

In order to ensure that welded fabrications consistently meet design requirements, welding must be designed into the fabrication from the drawing office - which should liaise with the workshop to produce a detailed "weld map" that details the sequence of welds and the length of welds, plus measures to prevent distortion and the specific placing of welds to avoid highly stressed areas.

Figure 1

Typical Joint Designs for Welding Aluminium
(From Aluminium Welding Theory and Practice)

Refer to Table 2 for further details and joint spacings

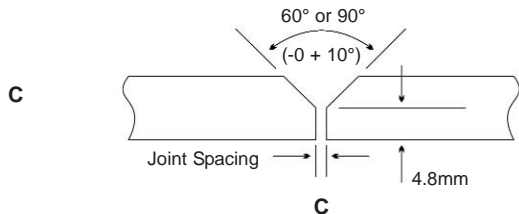
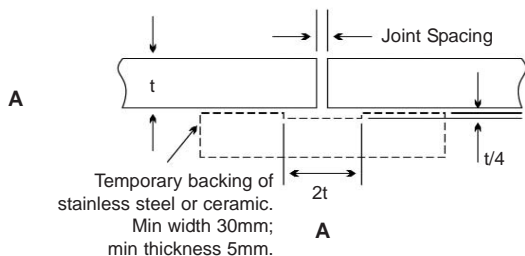

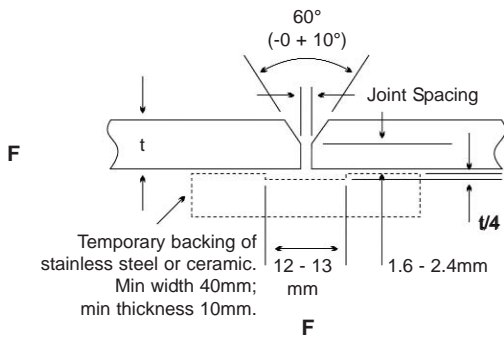
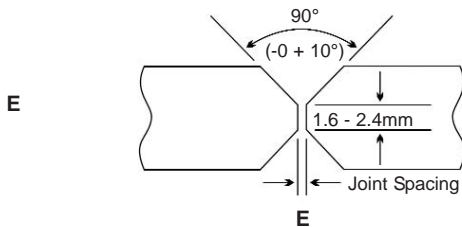
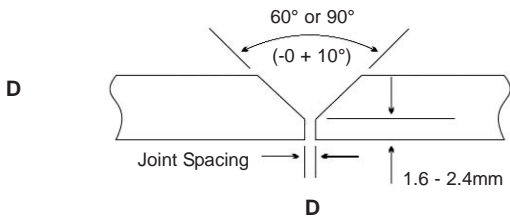

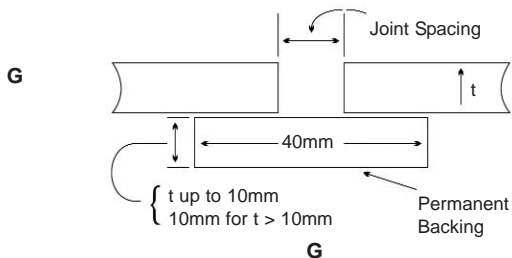

Corner and Edge Welds

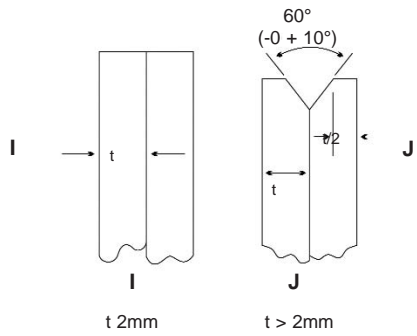
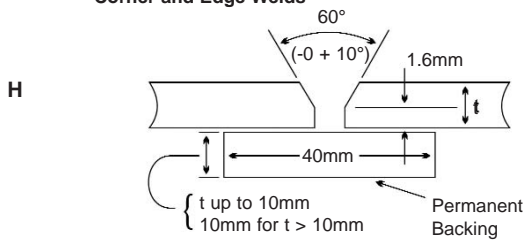



The Aluminium Fabricators Association (AFA) operates under the aegis of the Aluminium Federation of Southern Africa (AFSA).

AFSA's key objective is to promote the local fabrication of aluminium products - from locally produced alloys and semi-fabricated products and castings.

AFA has an active membership that serves a variety of market sectors in South Africa while also exporting value added aluminium products to other countries. The largest of AFSA's Associations, AFA's members operate in diverse market sectors from light to heavy engineering, transport, marine, power transmission, electricity and packaging - the heart of the down stream aluminium industry. AFA can supply design technology to the industry. AFA's members also include suppliers to and supporters of the aluminium fabrication industry and especially stockists.

Strong strategic alliances have been forged with a variety of technology based and educational institutions.

AFA concerns itself with the promotion and development of the fabrication industry, and especially its members, through a number of activities such as regular interaction between members to deal with matters of common technical or industry interest. It invites overseas experts in fabrication to address the Association and initiates and supports research into new technology.

Amongst the range of support offered, one of AFA's most important functions is seeking to promote industry standards with emphasis on international quality standards such as ISO 9000:2000 - with continuous improvement of the industry being a primary focus.

REFERENCE SOURCES USED IN THE COMPILATION OF THIS GUIDE:

- The Aluminium Association: Welding Aluminium Theory & Practice, 2nd edition, 1991
- Structural Welding Code. Aluminium AWS D1.2
- Skan Aluminium: Aluminium in product development, 1992
- Aluminium Welding Handbook: AFSA 1993
- Welding Aluminium: Alcan, 1977
- Guide to Welding Aluminium: Alcoa
- TALAT lecture notes: no 2203, 1994 concerning structural materials fabrication
- AFSA Library - various reference texts

AFSA has a number of reference sources on welding and joining of aluminium and its alloys, in its technical library.

Some of AFSA's members are welding consumable suppliers and some are fabricators. Both categories can be contacted for advice on aluminium welding.

Members and non-members are welcome to contact AFSA for more information (which is free to members).



Tel: 011 453 3339

Fax: 011 453 3403

Email: afsa@afsa.org.za

Website: www.afsa.org.za

This second edition [based on the first edition] was compiled and published by The Aluminium Federation of Southern Africa (AFSA) © 2004