

IST8303/IST8307 vs AK09915

IST8304 vs AK09915

IST8305 vs AK09911

IST8305 vs AK09916

Pin to Pin设计图解

# IST8303/IST8307 p2p to AK09915

需焊接C1脚位以及新增4.7uF电容

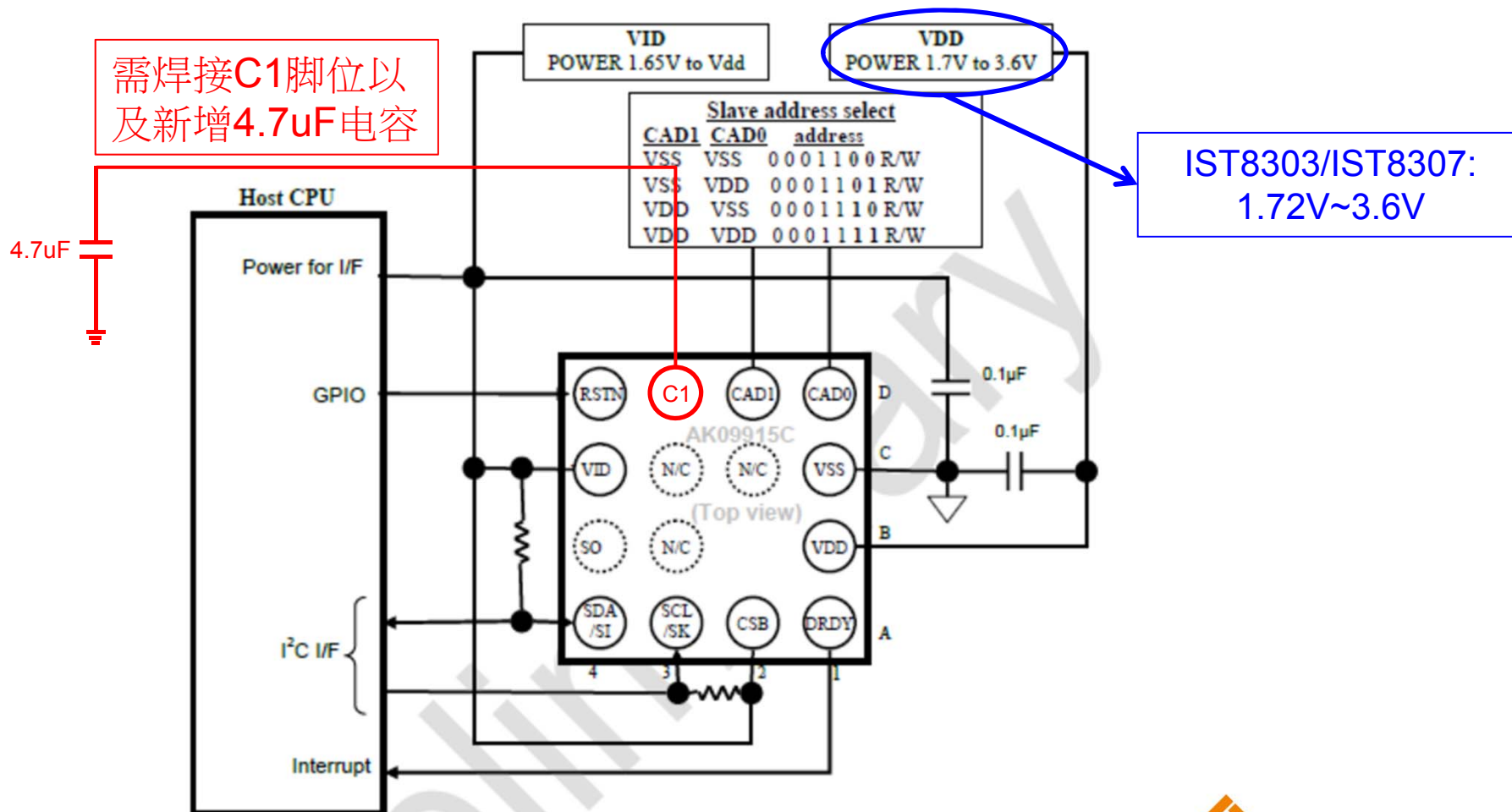

IST8303/IST8307:  
1.72V~3.6V

Pins of dot circle should be kept non-connected.

# IST8304 p2p to AK09915

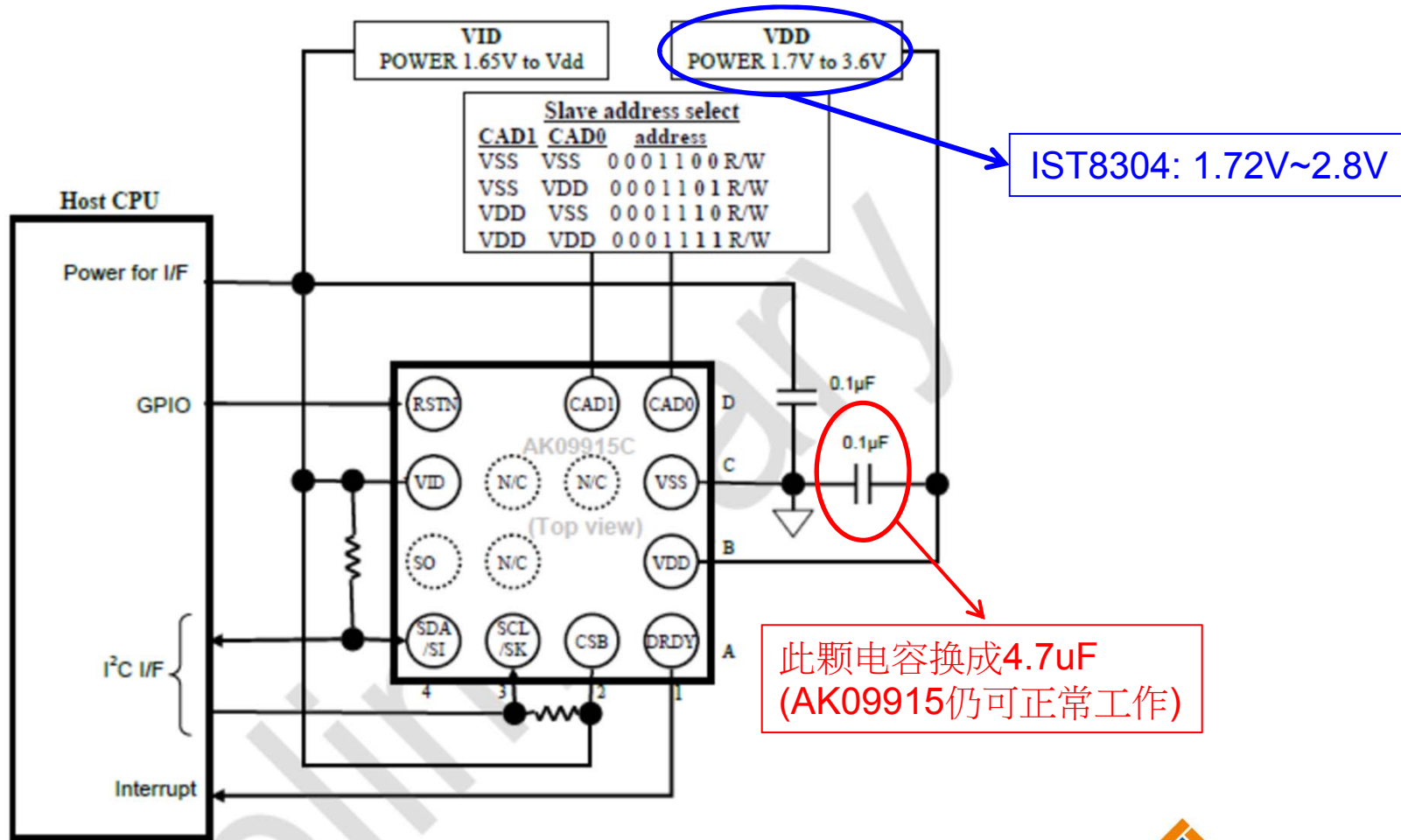

Pins of dot circle should be kept non-connected.

# IST8303/07 p2p to IST8304 & AK09915

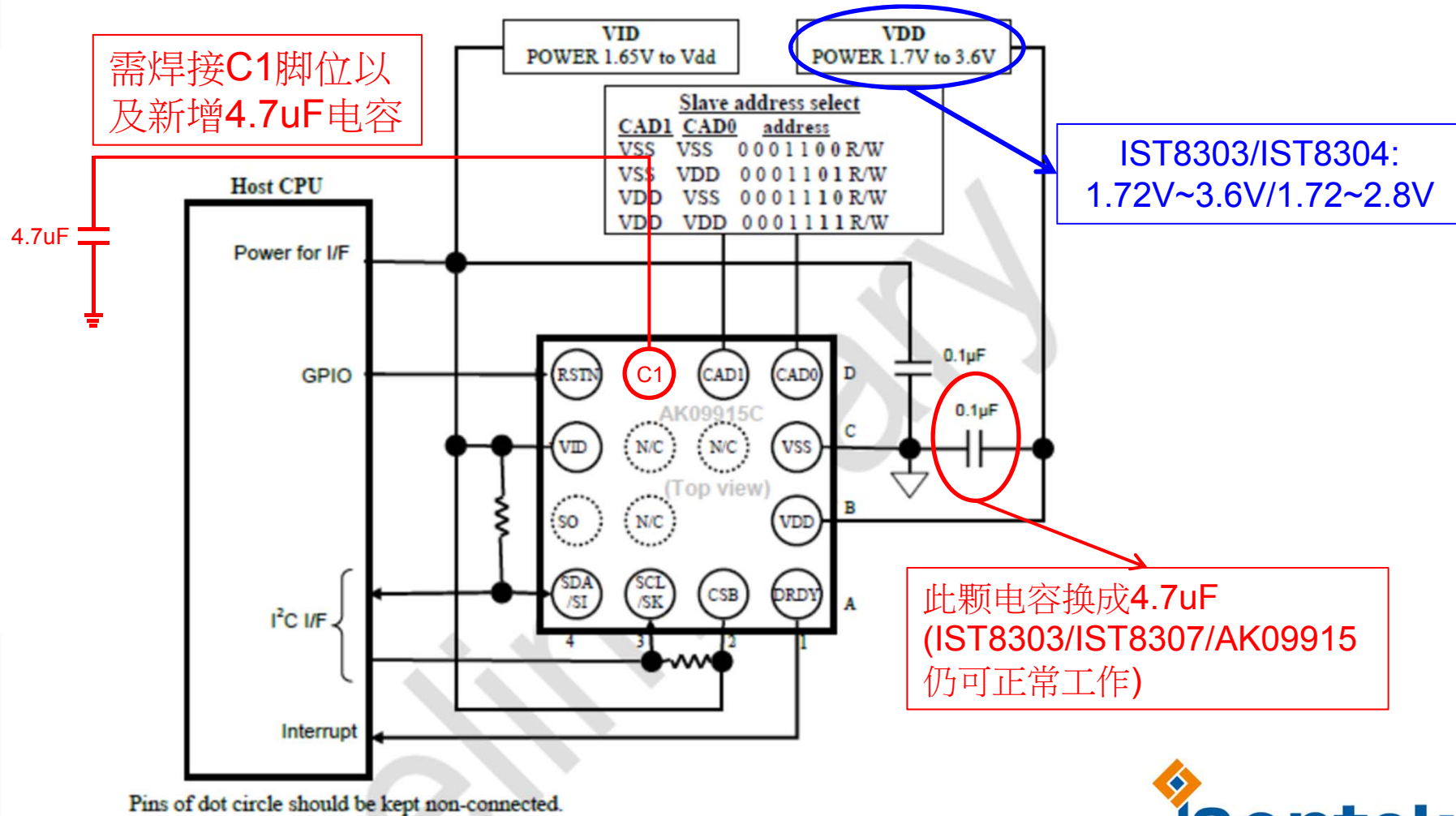

# IST8305 p2p to AK09911

IST8305ES: 1.75V~3.6V;  
IST8305MP: 1.6~3.6V

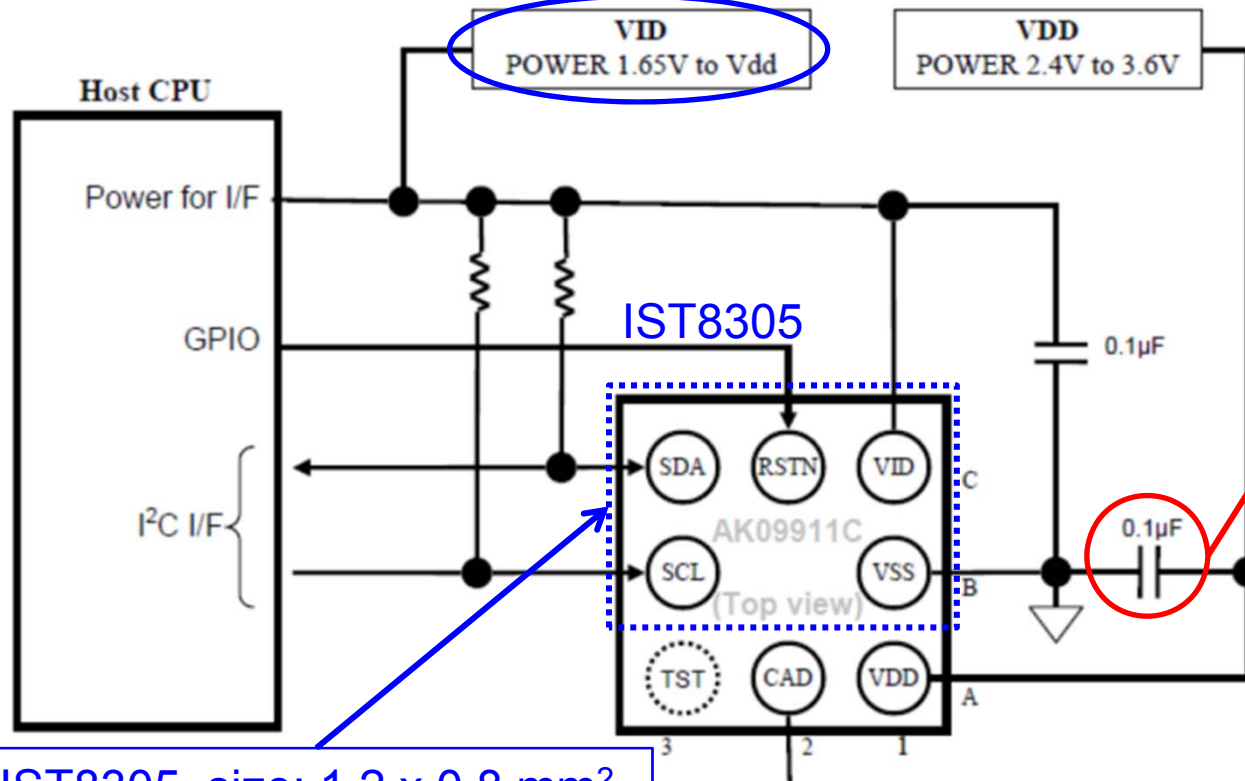

此顆电容换成4.7µF  
(AK09911仍可正常工作)

IST8305 size: 1.2 x 0.8 mm<sup>2</sup>  
AK09911 size: 1.2 x 1.2 mm<sup>2</sup>  
=> 只需焊接上半部分

# IST8305 p2p to AK09916

IST8305ES: 1.75V~3.6V;  
IST8305MP: 1.6~3.6V

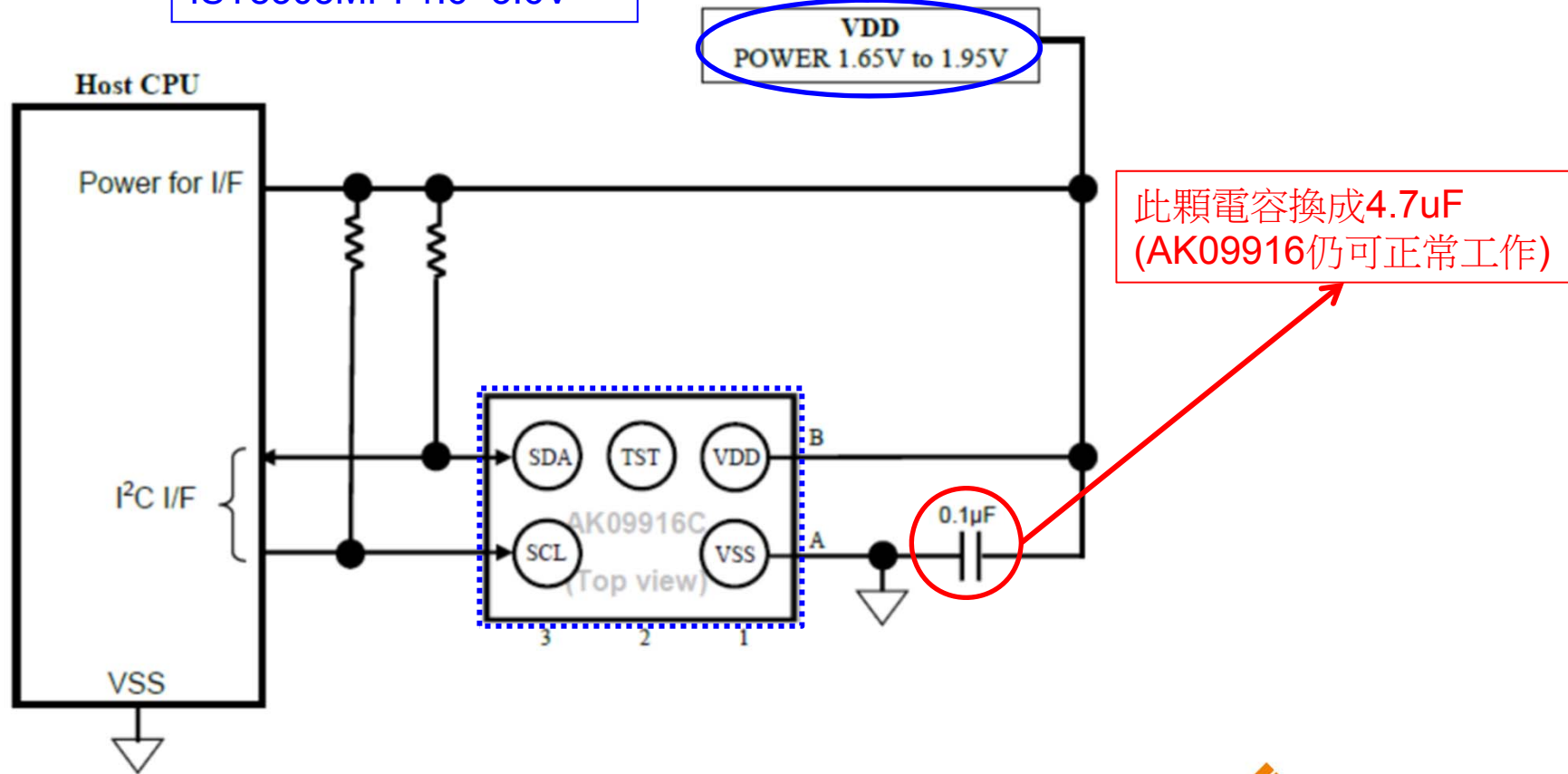

# IST8303/IST8307 Application Circuit

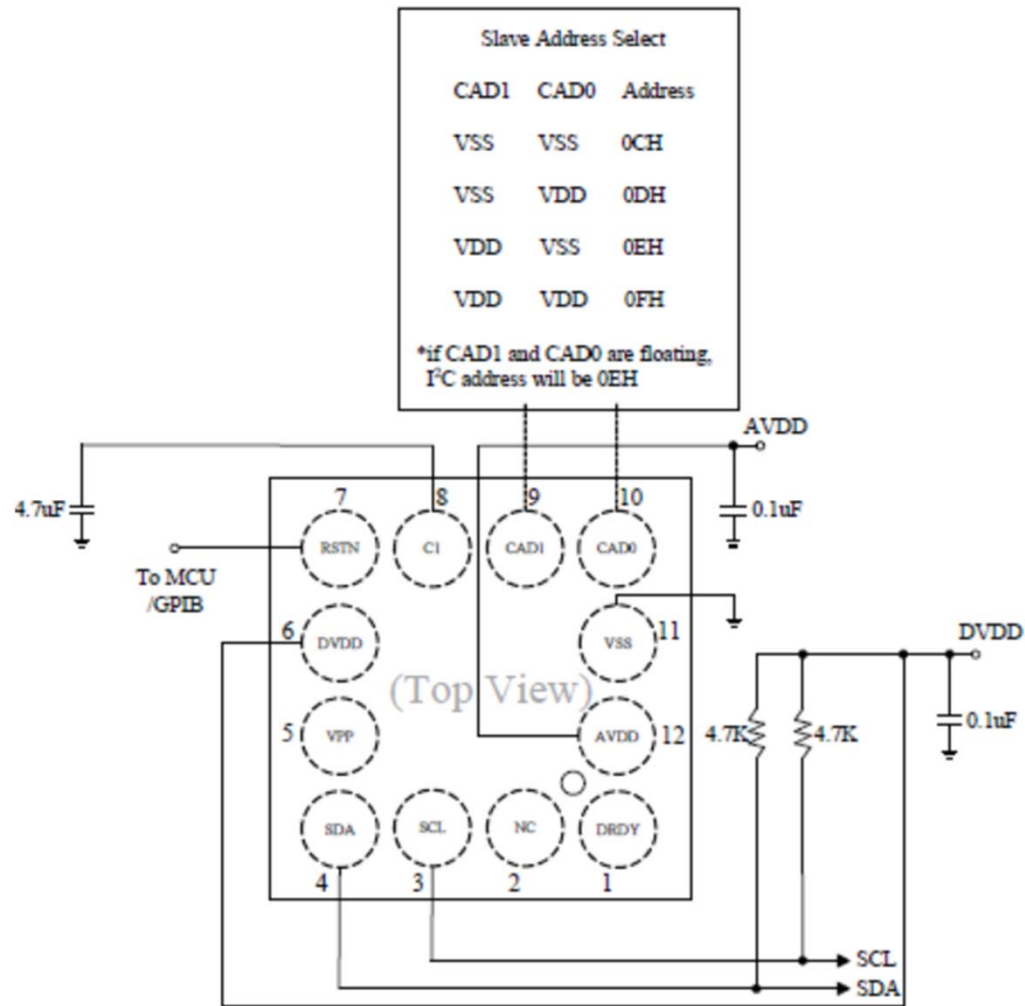

# IST8304 Application Circuit

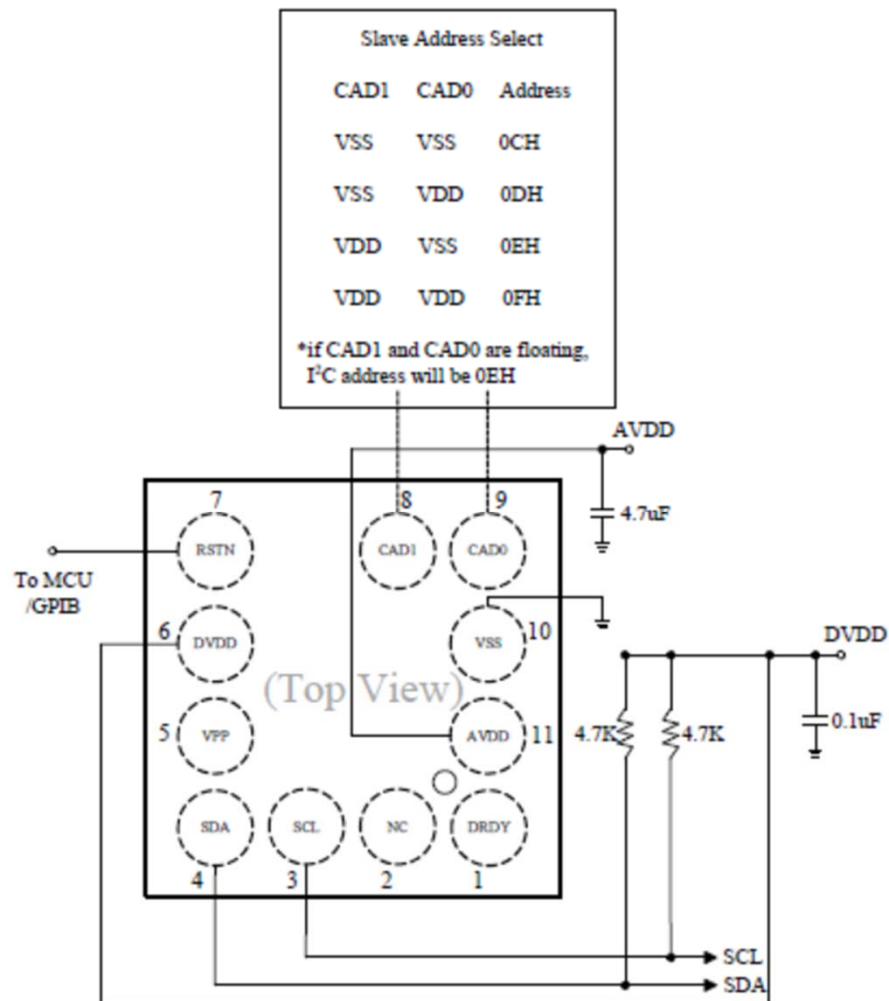



# IST8305 Application Circuit

